

Clinical Features and Outcome of Patients With IRAK-4 and MyD88 Deficiency

Capucine Picard, MD, PhD,* Horst von Bernuth, MD, PhD,* Pegah Ghandil, PhD, Maya Chrabieh, Ofer Levy, MD, PhD, Peter D. Arkwright, MD, Douglas McDonald, MD, PhD, Raif S. Geha, MD, Hidetoshi Takada, MD, Jens C. Krause, MD, C. Buddy Creech, MD, MPH, Cheng-Lung Ku, PhD, Stephan Ehl, MD, PhD, László Maródi, MD, Saleh Al-Muhsen, MD, Sami Al-Hajjar, MD, Abdulaziz Al-Ghonaium, MD, Noorbibi K. Day-Good, PhD, Steven M. Holland, MD, PhD, John I. Gallin, MD, Helen Chapel, MD, David P. Speert, MD, Carlos Rodriguez-Gallego, MD, Elena Colino, MD, Ben-Zion Garty, MD, Chaim Roifman, MD, Toshiro Hara, MD, PhD, Hideto Yoshikawa, MD, Shigeaki Nonoyama, MD, Joseph Domachowske, MD, Andrew C. Issekutz, MD, Mimi Tang, MD, Joanne Smart, MD, Simona Eva Zitnik, MD, Cyrille Hoarau, MD, Dinakantha S. Kumararatne, MD, Adrian J. Thrasher, MD, PhD, E. Graham Davies, MD, Claire Bethune, MD, Nicolas Sirvent, MD, Dominique de Riccaud, MD, Yildiz Camcioglu, MD, Júlia Vasconcelos, MD, Margarida Guedes, MD, Artur Bonito Vitor, MD, Carlos Rodrigo, MD, Francisco Almazán, MD, Maria Méndez, MD, Juan Ignacio Aróstegui, MD, PhD, Laia Alsina, MD, Claudia Fortuny, MD, Janine Reichenbach, MD, PhD, James W. Verbsky, MD, PhD, Xavier Bossuyt, MD, PhD, Rainer Doffinger, PhD, Laurent Abel, MD, PhD, Anne Puel, PhD, and Jean-Laurent Casanova, MD, PhD

Abstract: Autosomal recessive interleukin-1 receptor-associated kinase (IRAK)-4 and myeloid differentiation factor (MyD)88 deficiencies impair Toll-like receptor (TLR)- and interleukin-1 receptor-mediated immunity. We documented the clinical features and outcome of 48 patients with IRAK-4 deficiency and 12 patients with MyD88 deficiency, from 37 kindreds in 15 countries.

The clinical features of IRAK-4 and MyD88 deficiency were indistinguishable. There were no severe viral, parasitic, and fungal diseases, and the range of bacterial infections was narrow. Noninvasive bacterial infections occurred in 52 patients, with a high incidence of infections of the upper respiratory tract and the skin, mostly caused by *Pseudomonas aeruginosa* and *Staphylococcus aureus*, respectively. The leading threat was invasive pneumococcal disease, documented in 41 patients (68%) and causing 72 documented invasive infections (52.2%). *P. aeruginosa* and *Staph. aureus* documented invasive infections also occurred (16.7% and 16%, respectively, in 13 and 13 patients, respectively). Systemic signs of inflammation were usually weak or delayed. The first invasive infection occurred before the age of 2 years in 53 (88.3%) and in the neonatal period in 19 (32.7%) patients. Multiple or recurrent invasive infections were observed in most survivors (n = 36/50, 72%).

Clinical outcome was poor, with 24 deaths, in 10 cases during the first invasive episode and in 16 cases of invasive pneumococcal disease. However, no death and invasive infectious disease were reported in patients after the age of 8 years and 14 years, respectively. Antibiotic

prophylaxis (n = 34), antipneumococcal vaccination (n = 31), and/or IgG infusion (n = 19), when instituted, had a beneficial impact on patients until the teenage years, with no seemingly detectable impact thereafter.

IRAK-4 and MyD88 deficiencies predispose patients to recurrent life-threatening bacterial diseases, such as invasive pneumococcal disease in particular, in infancy and early childhood, with weak signs of inflammation. Patients and families should be informed of the risk of developing life-threatening infections; empiric antibacterial treatment and immediate medical consultation are strongly recommended in cases of suspected infection or moderate fever. Prophylactic measures in childhood are beneficial, until spontaneous improvement occurs in adolescence.

(*Medicine* 2010;89: 403–425)

Abbreviations: CRP = C-reactive protein, ELISA = enzyme-linked immunosorbent assay, IFN = interferon, IKBA = IκBα, IL = interleukin, IL-1R = interleukin-1 receptor, InvBD = invasive bacterial disease, IRAK = interleukin-1 receptor-associated kinase, MyD = myeloid differentiation factor, NEMO = nuclear factor-κappaB essential modulator, NInvBD = noninvasive bacterial disease, TIR = Toll/IL-1R, TLR = Toll-like receptor, TNF = tumor necrosis factor.

From Study Center of Primary Immunodeficiencies, Assistance Publique Hôpitaux de Paris (CP); Necker Hospital, Paris, France. Laboratory of Human Genetics of Infectious Diseases (CP, HvB, PG, MC, CLK, L. Abel, AP, JLC), Necker Branch, INSERM U980, Paris, France. Paris Descartes University (CP, HvB, PG, MC, CLK, L. Abel, AP, JLC), Paris, France. Department of Pediatric Pneumology and Immunology (HvB), Charité Hospital-Humboldt University, Berlin, Germany. Prince Naif Center for Immunology Research (PG, SAM, SAH, AAG, JLC), College of Medicine, King Saud University, Riyadh, Saudi Arabia. Division of Infectious Diseases (OL); and Division of Immunology (DM, RSG), Children's Hospital Boston (OL), Boston, Massachusetts. Harvard Medical School (OL, DM, RSG), Boston, Massachusetts. University of Manchester (PDA), Royal Manchester Children's Hospital, Manchester, United Kingdom. Department of Pediatrics (HT, TH), Graduate School of Medical Sciences, Kyushu University, Fukuoka, Japan. Copyright © 2010 by Lippincott Williams & Wilkins
ISSN: 0025-7974
DOI: 10.1097/MD.0b013e3181fd8ec3

Department of Pediatrics (JCK, CBC), Division of Pediatric Infectious Diseases, Vanderbilt University, Nashville, Tennessee. Centre of Chronic Immunodeficiency (SE), University of Freiburg, Freiburg, Germany. Department of Infectious and Pediatric Immunology (LM), Medical and Health Science Center, University of Debrecen, Debrecen, Hungary. Department of Pediatrics (SAM, SAH, AAG), King Faisal Specialist Hospital and Research Centre, Riyadh, Saudi Arabia. Department of Pediatrics (NKDG), Division of Allergy and Immunology, University of South Florida and All Children's Hospital, St. Petersburg, Florida. Laboratory of Clinical Infectious Diseases (SMH, JIG), National Institute of Allergy and Infectious Diseases, National Institutes of Health, Bethesda, Maryland. University of Oxford and Oxford Radcliffe Hospital (HC), Oxford, United Kingdom. Division of Infectious and Immunological Diseases (DPS), Department of Pediatrics, University of British Columbia, Vancouver, British Columbia, Canada. Department of Immunology (CRG), Dr Negrin University Hospital of Gran Canaria, Las Palmas de Gran Canaria, Spain. Department of Pediatrics (EC), Unit of Infectious Diseases, Insular-Materno-Infantil University Hospital, Las Palmas

INTRODUCTION

Autosomal recessive interleukin-1 receptor-associated kinase (IRAK)-4 and myeloid differentiation factor (MyD)88 deficiencies are recently described primary immunodeficiencies.^{38,49} MyD88 is a key cytosolic adapter molecule, providing a bridge from Toll-like receptors (TLRs) and interleukin-1 receptors (IL-1Rs) to the IRAK complex, which consists of 2 active kinases (IRAK-1 and IRAK-4) and 2 noncatalytic subunits (IRAK-2 and IRAK-3/M). MyD88 interacts with TLRs and IL-1Rs via a shared Toll and IL-1R (TIR) domain. The MyD88- and IRAK-4-dependent TIR pathway leads to the synthesis of inflammatory cytokines, such as IL-1 β , IL-6, IL-8, tumor necrosis factor (TNF)- α , interferon (IFN)- α/β , and IFN- λ , at least after TLR7, TLR8, and TLR9 stimulation (Figure 1).¹ MyD88 and IRAK-4 deficiencies can thus be considered phenocopies with respect to their immunologic phenotype.⁴⁹ Blood leukocytes derived from MyD88- and IRAK-4-deficient patients display impaired responses to most of the TLR and IL-1R agonists tested.^{38,49} All human TLRs other than TLR3 use both MyD88 and IRAK-4.^{42,43} This pathway is also used by a number of IL-1Rs, including IL-1R, IL-18R, and IL-33Ra (ST2).^{3,17} (unpublished data) It is unknown whether other TIR-containing IL-1Rs, such as IL-1Rrp-2, SIGIRR/TIR8, TIGIRR-1, and TIGIRR-2/IL-1RAPL, use MyD88 and IRAK-4.^{17,41} IL-1 α and IL-33 may also exert alternative, intracellular effects leading to transcriptional regulation.¹⁷ To our knowledge, no mutation affecting the MyD88-independent IL-1R pathway has yet been identified. An alternative, MyD88-independent but TRIF-dependent pathway can be triggered by TLR-3 and TLR-4. The alternative TLR-3 pathway is impaired in patients with UNC-93B and TLR-3 deficiencies, whose alternative TLR-4 pathway is not affected.^{11,54} By contrast, mutations in NEMO and IKBA genes are associated with a much broader signaling defect, including both the classical and alternative pathways.⁷

Given such a broad and profound immunologic phenotype, we would expect the clinical infectious phenotype of IRAK-4 and MyD88 deficiencies to be extremely severe. However, available clinical data for 45 patients with MyD88 and IRAK-4 deficiencies suggest instead a narrow susceptibility to invasive bacterial infections, mostly caused by gram-positive bacteria,

such as *Streptococcus pneumoniae* and *Staphylococcus aureus* in particular, with rare infections caused by gram-negative bacteria, such as *Pseudomonas aeruginosa* and *Shigella sonnei*.^{6,19,25,26,38,49}

Both MyD88- and IRAK-4-deficient patients seem to have normal resistance to common fungi, parasites, viruses, and to a large fraction of bacteria. Moreover, although 16 of the 45 reported patients died in childhood, the clinical features of the survivors seemed to improve with age.^{6,8,12,14-16,18-20,23-27,30,32,38,44,52} The clinical history of these patients seems otherwise unremarkable, with the exception of a late detachment of the umbilical cord, reported in 2 patients.⁴⁴

This clinical information, however, is based principally on the description of individual case reports and small series of patients, with a single large series of 28 individuals.²⁵ Moreover, most publications, including that dealing with the large series,²⁵ have focused on the genotype and cellular phenotype of patients, providing little clinical information—infectious and immunologic information in particular. To our knowledge, the actual clinical presentation of patients with MyD88 and IRAK-4 deficiency and their overall immunologic evaluation have yet to be described. The nature and severity of the infectious diseases to which these patients are susceptible and the impact of prophylaxis and age on clinical outcome have not been described. The impact of these defects on the development and function of the myeloid and lymphoid cell subsets also remains to be characterized. We therefore undertook a detailed and thorough description of the clinical features and outcome of an international series of patients with MyD88 or IRAK-4 deficiency.

PATIENTS AND METHODS

Subjects and Kindreds

The current study was conducted in accordance with the Helsinki Declaration, with informed consent obtained from each patient or the patient's family. The study was approved by the local ethics committee of Necker-Enfants Malades Hospital, Paris, France. A detailed questionnaire was completed by the physicians caring for the patients with MyD88 and IRAK-4 deficiencies and sent to 2 of the authors (CP and HvB) for thorough review. During follow-up, communications were sent

de Gran Canaria, Spain. Schneider Children's Medical Center (BZG), Petah Tikva, Israel. Division of Immunology and Allergy (C. Roifman), Department of Pediatrics, Hospital for Sick Children, University of Toronto, Toronto, Ontario, Canada. Department of Neurology (HY), Miyagi Children's Hospital, Sendai, Japan. Department of Pediatrics (SN), National Defense Medical College, Saitama, Japan. Pediatrics, Microbiology and Immunology (JD), SUNY Upstate Medical University, Syracuse, New York. Dalhousie University (ACI), Halifax, Nova Scotia, Canada. Royal Children's Hospital (MT, JS), Parkville, Victoria, Australia. University Children Hospital Ljubljana (SEZ), Ljubljana, Slovenia. Unité transversale d'Allergologie, Néphrologie et Immunologie Clinique (CH), Centre hospitalier universitaire de Tours, Tours, France. Department of Clinical Biochemistry and Immunology (DSK, RD), Addenbrookes Hospital, Cambridge, United Kingdom. Paediatric Immunology and Molecular Immunology Unit (AJT), Institute of Child Health, London, United Kingdom. Department of Clinical Immunology (EGD), Great Ormond St Hospital, London, United Kingdom. Immunology Department (CB), Derriford Hospital, Plymouth, United Kingdom. University Hospital Archet 2 (NS), Nice, France. Lenval Foundation (DDR), Children's Hospital, Nice, France. Cerrahpasa Medical School (YC), Istanbul University, Istanbul, Turkey. Clinical Pathology and Pediatric Department (JV, MG), General Hospital of Santo António, Porto, Portugal. Pediatric Department (ABV), Hospital S. João, Porto, Portugal. Pediatric Department (C. Rodrigo, FA, MM), Germans Trias i Pujol Hospital, Barcelona Autonomous University, Barcelona, Spain. Immunology Department-CDB (JA), Hospital Clinic-IDIBAPS, Barcelona University, Barcelona, Spain. Pediatric Department (L. Alsina, CF), Hospital Sant Joan de Deu, Barcelona University, Barcelona, Spain. Immunology Department (JR), Universitäts-Kinderspital Zürich, Zürich, Switzerland. Pediatrics

and Microbiology and Molecular Genetics (JMV), Medical College of Wisconsin, Milwaukee, Wisconsin. Experimental Laboratory Medicine (XB), Department of Medical Diagnostic Sciences, Biomedical Science Group, Catholic University Leuven, Leuven, Belgium. St. Giles Laboratory of Human Genetics of Infectious Diseases (JLC), Rockefeller Branch, The Rockefeller University, New York, New York. Pediatric Hematology-Immunology Unit (JLC), Necker Hospital, Assistance Publique Hôpitaux de Paris, Paris, France.

*Both authors contributed equally to this work.

Financial support: The St. Giles Laboratory of Human Genetics of Infectious Diseases is supported by grants from The Rockefeller University Center for Clinical and Translational Science grant number SUL.IRR024143-03 and The Rockefeller University. The Laboratory of Human Genetics of Infectious Diseases was supported by the March of Dimes, the Dana Foundation, the ANR, INSERM, and PHRC. HvB received funding from the University San Raffaele (Milan, Italy), the LeGs Poix (Paris, France), and the Deutsche Forschungsgemeinschaft (DFG VO 995/1-1, VO 995/1-2, BE 3895/3-1) (Bonn, Germany). OL received funding from NIH-NIAID-RO1 AI067353-01A1. JLC was an International Scholar of the Howard Hughes Medical Institute. Reprints: Jean-Laurent Casanova, MD, PhD, St. Giles Laboratory of Human Genetics of Infectious Diseases, The Rockefeller University, 1230 York Avenue, New York, NY 10021, USA (e-mail: jean-laurent.casanova@rockefeller.edu); or Capucine Picard, MD, PhD, Laboratory of Human Genetics of Infectious Diseases, INSERM U980- Necker Faculty, 156 rue de Vaugirard, 75015, Paris, France (e-mail: capucine.picard@inserm.fr).

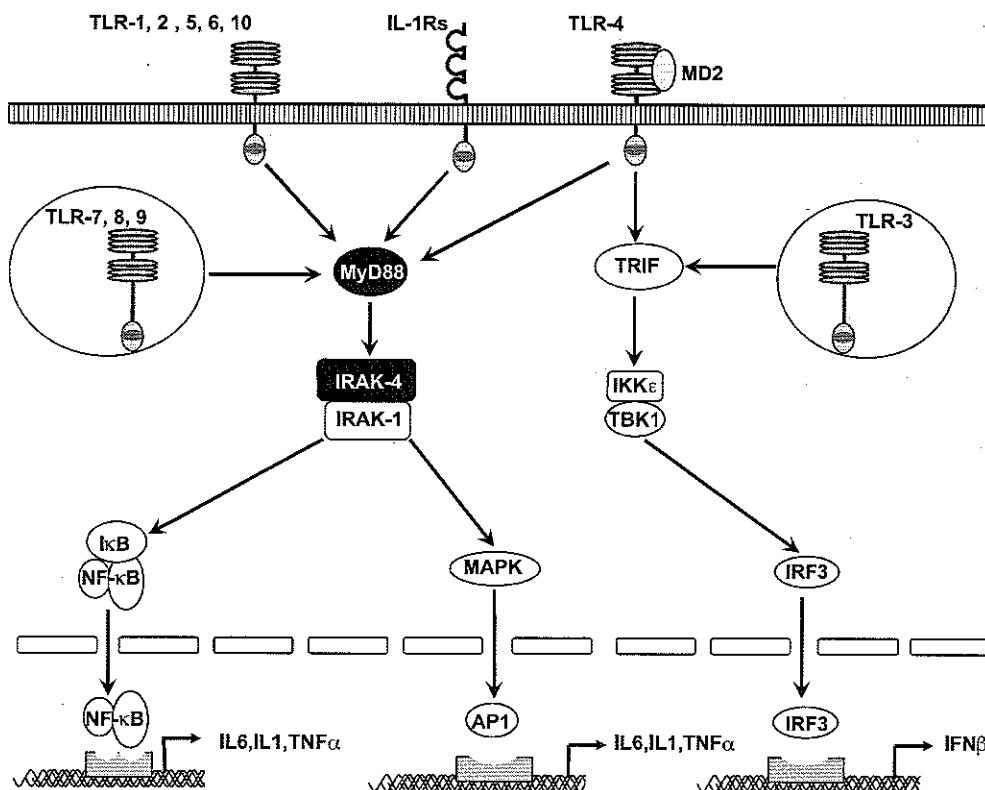

FIGURE 1. Schematic representation of TIRs signaling pathway. MyD88 interacts with TLRs and IL-1Rs through a shared TIR domain. MyD88 is a key cytosolic adapter molecule, providing a bridge from TLRs and IL-1Rs to the 2 active kinases IRAK-4 and IRAK-1. IRAK-4 and IRAK-1 then activate at least the 2 signaling NF-κB and MAPK pathways. The MyD88- and IRAK-4-dependent TIR pathway leads among others to the synthesis of inflammatory cytokines, such as IL-1β, IL-6, IL-8, TNF-α, and to IFN-α/β and IFN-λ, at least for TLR7, TLR8 and TLR9. The MyD88- and IRAK-4-independent TIR pathway uses TRIF pathway after stimulation of TLR3 and TLR4. This pathway is important for IFN-α and IFN-β production.

to confirm clinical information, including the prevalence, clinical presentation, and histologic features of noninvasive infections, such as otitis media, dermatitis, lymphadenitis, and necrotizing pharyngitis. Clinical and laboratory data were collected for the patients from their birth until December 2009, or until their death if they died before this date.

Activation by TLR Agonists and Cytokine Determinations

The activation of cells in whole-blood samples and the levels of TNF-α and IL-6 secretion were determined by enzyme-linked immunosorbent assay (ELISA), as previously described.²⁵ Granulocytes were isolated by Ficoll density gradient centrifugation, activated with TLR agonists, stained with anti-CD62L-FITC (BD) antibody, and analyzed by flow cytometry, as previously described.⁴⁸ Twenty kindreds with IRAK-4 deficiency and the 6 kindreds with MyD88 deficiency were explored in our laboratory, by 1 or by both exploratory methods. The remaining 11 kindreds with IRAK-4 deficiency were identified by other teams.

Sequencing Analysis

Genomic DNA was isolated by phenol/chloroform extraction. RNA was isolated with Trizol (GibcoBRL Life Technologies, Invitrogen SARL). Genomic DNA and cDNAs for IRAK4 and MYD88 were amplified, sequenced, and analyzed on an ABI Prism 3700 apparatus (BigDye Terminator sequencing kit, Applied Biosystems), as previously described.²⁵ Twenty kindreds with IRAK-4 deficiency and the 6 kindreds with MyD88 defi-

ciency were identified in our laboratory by sequencing analysis. The remaining 11 kindreds with IRAK-4 deficiency were identified by other teams.

Western Blotting

Proteins for Western blotting were extracted from peripheral blood mononuclear cells, Epstein-Barr virus-transformed B cells, and SV40-transformed fibroblasts. Western blots were probed with rabbit antibodies against IRAK-4 (Tularik and Cell Signaling Technology), MyD88 (CSA-510, Stressgen), and glyceraldehyde-3-phosphate dehydrogenase (GAPDH) (Santa Cruz Biotechnology, Inc.).

Immunologic Investigations

Immunologic investigations were based on those described in previous studies and/or the questionnaires sent to physicians. Lymphocyte subsets were determined by routine flow cytometry. Serum levels of the IgM, IgA, IgG, and IgG subclasses were assessed by standard nephelometry techniques. Total IgG antibody levels against multiple pneumococcal serotypes (23 serotypes),^{5,22} levels of IgG against *Haemophilus influenzae* PRP antigens, tetanus toxoid, and diphtheria were assessed by standard ELISA techniques. We carried out a prospective study in 9 IRAK-4-deficient patients, for whom antibody titers against serotype-specific pneumococcal capsular polysaccharides were determined, as previously described, before and after immunization with nonconjugate antipneumococcal vaccine.^{22,50} The United States Pneumococcal Reference Serum Lot 89-SF was

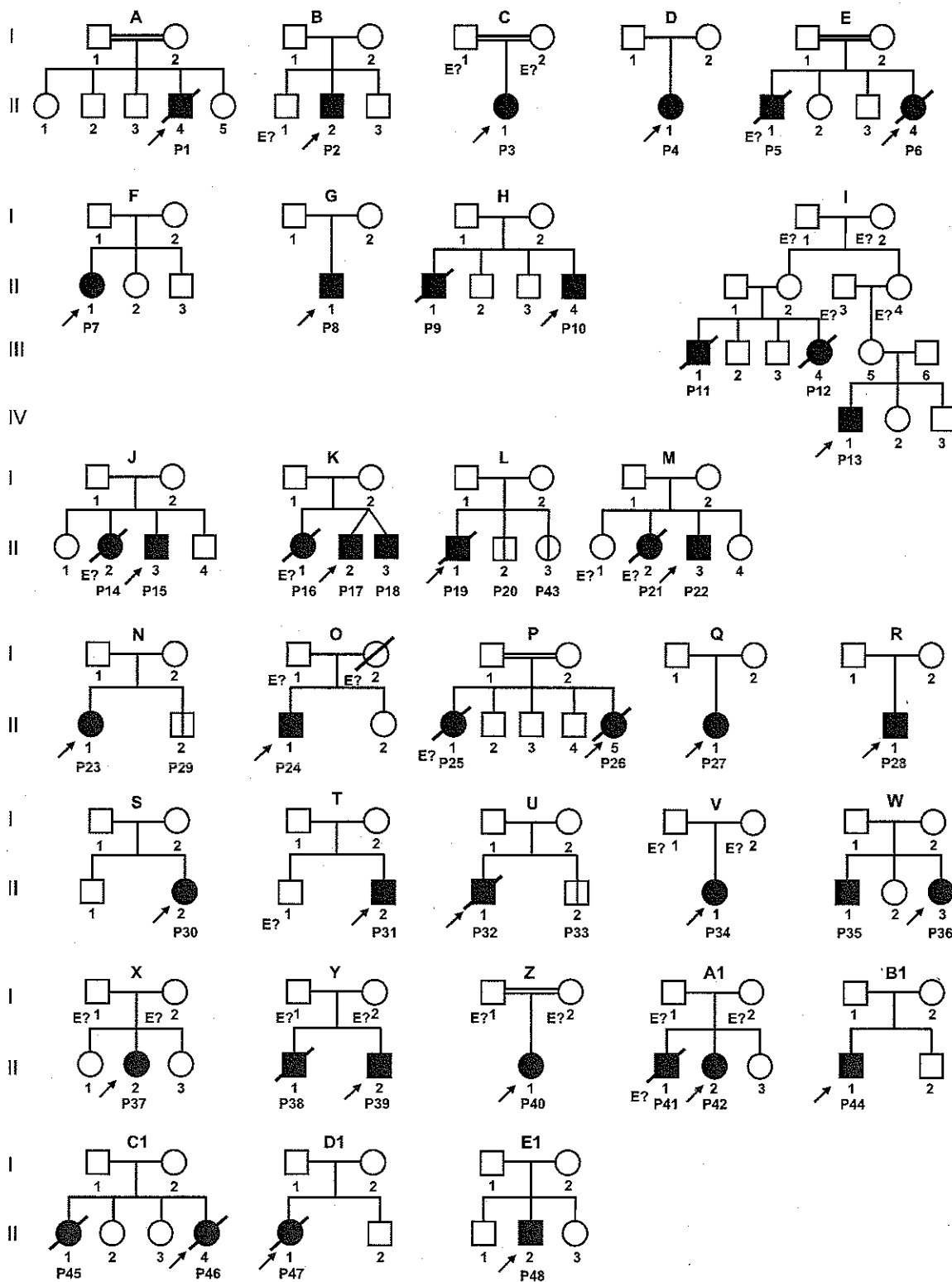

FIGURE 2. Pedigrees of the 31 kindreds identified with IRAK-4 deficiency. Each kindred with IRAK-4 deficiency is designated by a capital letter (A–E1) each generation is designated by a Roman numeral (I–IV), and each individual is designated by an Arabic numeral (from left to right). Patients with a clinical phenotype are indicated by closed symbols. Patients with confirmed IRAK-4 deficiency but no clinical phenotype as yet are indicated by an open square or circle divided by a black line. In each family, the proband is indicated by an arrow. Individuals whose genetic status could not be evaluated are indicated by “E?”.

used as a reference. We determined IgG concentrations against serotype 3 (a strong immunogen), serotypes 4, 14, and 19F (intermediate immunogens), and serotypes 6B, 9N, and 18C (weak immunogens). A normal response is defined as an increase in antibody titers by a factor of at least 3. All antibody determinations were performed before or several months after the end of immunoglobulin treatment.

Statistical Analysis

Infection-free status and survival curves as a function of age were estimated by the Kaplan-Meier method, and, when necessary, curves were compared by log-rank tests.

RESULTS

Description of Patients and Kindreds

We studied 48 patients (26 male and 22 female patients) from 31 kindreds with IRAK-4 deficiency (kindred A to E1)^{6,8,12,14-16,18,20,23-25,27,30,32,38,44} (present report) and 12 patients (7 male and 5 female patients) from 6 kindreds with MyD88 deficiency (kindred a to f)⁴⁹ (present report) (Figures 2 and 3; Table 1). This series includes all 45 patients (36 IRAK-4 and 9 MyD88) described in previous reports (24 and 5 kindreds, respectively) and 15 newly diagnosed patients (12 IRAK-4 and 3 MyD88 patients, corresponding to 7 kindreds and 1 kindred, respectively). In all probands, diagnosis was based on the detection of homozygous or compound heterozygous mutations in IRAK4 or MYD88 accompanied by a lack of production of IL-6 by whole blood or of CD62L shedding from granulocytes following activation with TLR/IL-1Rs agonists.^{38,48,49} In addition, 16 relatives were found to be homozygous or compound heterozygous for mutations in IRAK4 or MYD88. Finally, 7 sibs who had died of bacterial infection were considered to have IRAK-4 or MyD88 deficiency retrospectively, by inference from the personal and familial history.

The parents were consanguineous in 7 of the 37 kindreds. Up to 18 cases were sporadic, whereas 42 cases were familial (19 kindreds). The 37 families originated from 15 countries on

4 continents, including North America (Canada, El Salvador, United States), Asia (Israel, Japan, Saudi Arabia, Turkey), Australia, and Europe (France, Hungary, Portugal, Serbia, Slovenia, Spain, United Kingdom). Most patients and their families were living in their countries of origin, with the exception of a Portuguese family living in France, a Serbian family living in Switzerland, a Turkish family living in Germany, and a family from El Salvador living in the United States (Figure 4; Table 1).

IRAK4 and MYD88 Mutations

Patients with IRAK-4 deficiency were homozygous in 17 kindreds, whereas those from 14 other kindreds were compound heterozygous for IRAK4 mutations (Table 1). One seemingly homozygous patient (B-P2) was actually compound heterozygous for the Q293X mutation, inherited from his mother, and for a large de novo deletion (designated BAC210N13del) encompassing the IRAK4 gene.²⁵ Two other patients from the same family (I-P11 and I-P12) had 1 parent who did not carry the mutant allele. Not enough material was available to explore the IRAK4 locus further in deceased patients P11 and P12 from kindred I.⁸ Two of the newly identified mutations were nonsense mutations (R183X and Y430X), 1 was a splice mutation (I126-I G>T), 2 were frameshift insertions and deletions (43insA and 897_900delCAT), and 2 were missense mutations (M1V and G298D). All the mutations other than the missense mutations were predicted to be loss-of-expression and loss-of-function, as they create a premature termination codon or delete a large segment of the gene. The M1V mutation affecting the initiation codon was also likely to be severely deleterious. No IRAK-4 protein was detected in the patient bearing the M1V/1188+520A>G mutant alleles, whereas the patient bearing the G298D mutation at compound heterozygous state (G298D/Q293X) did produce IRAK-4 protein in peripheral blood mononuclear cells and in B cell lines. All the previously reported mutations are loss-of-expression,²⁵ with the exception of the R12C and 831+5G>T mutant alleles in patient T-P31, which are associated with residual IRAK-4 protein production.²⁰

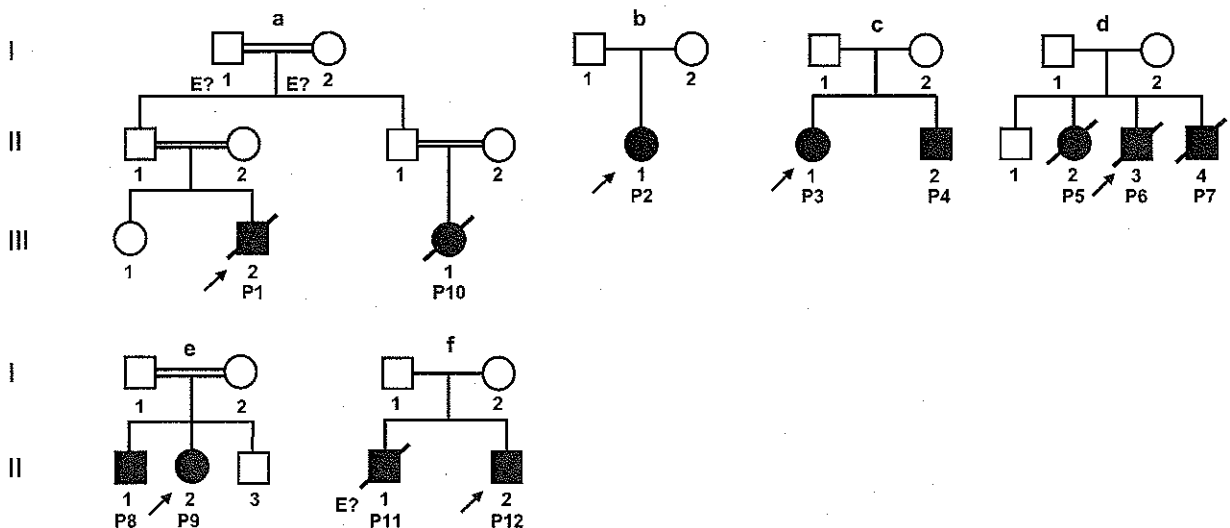

FIGURE 3. Pedigrees of the 6 kindreds with MyD88 deficiency identified. Each kindred with MyD88 deficiency is designated by a lower case letter (a-f); each generation is designated by a Roman numeral (I-IV), and each individual is designated by an Arabic numeral (from left to right). Patients with a clinical phenotype are indicated by closed symbols. In each family, the proband is indicated by an arrow. Individuals whose genetic status could not be evaluated are indicated by "E?".

TABLE 1. Country of Origin, Genotype, Infectious Phenotype, and Outcome in the Cohort of IRAK-4- and MyD88-Deficient Patients

Kindred	P	Age/Sex (yr)	Mutation of IRAK4	Country of Origin	Outcome Status	Invasive Infections With Gram-Positive Bacteria	Invasive Infections With Gram-Negative Bacteria	Other	Ref.
A	1	7/M	821delT/821delT	Saudi Arabia	†	<i>S. pneumoniae</i> , <i>S. aureus</i>			38
B	2	17/M	Q293X/BAC210N13del	Portugal	Alive	<i>S. pneumoniae</i> , <i>S. aureus</i>			25,38
C	3	14/F	Q293X/Q293X	USA	Alive	<i>S. pneumoniae</i> , <i>S. aureus</i>		<i>Enterovirus</i> , <i>Curvularia</i> species	15,19,25,38
D	4	27/F	Q293X/620-621delAC	USA	Alive	<i>S. pneumoniae</i> , <i>C. septicum</i>	<i>N. meningitidis</i>		25,26,32
E	5	16 mo/M	ND	Turkey	†	<i>S. pneumoniae</i> , <i>S. parvus</i>			18
E	6	2 mo/F	523delA/523delA	Turkey	†	<i>S. pneumoniae</i> ,			18
F	7	35/F	Q293X/Q293X	UK	Alive	<i>S. pneumoniae</i> ,	<i>S. sonnei</i>		12,25
G	8	11/M	1189-1G>T/ 1188+520A>G	Hungary	Alive	<i>S. pneumoniae</i>			24,25
H	9	5.5/M	Q293X/Q293X	Canada	†	<i>S. pneumoniae</i>	<i>P. aeruginosa</i>		14,25
H	10	10/M	Q293X/Q293X	Canada	Alive	<i>S. pneumoniae</i>			14,25
I	11	2.5/M	E402X/del (?)	Spain	†	<i>S. aureus</i>	<i>P. aeruginosa</i>		8,25
I	12	8 mo/F	E402X/del (?)	Spain	†	<i>S. pneumoniae</i>	<i>P. aeruginosa</i>		8,25
I	13	12/M	E402X/ E402X	Spain	Alive	<i>S. pneumoniae</i>			8,25
J	14	3 mo/F	ND	Israel	†	<i>S. milleri</i>			25
J	15	12/M	1-1096_40+23del/ 1-1096_40+23del	Israel	Alive	<i>S. pneumoniae</i>			25
K	16	5 mo/F	ND	Canada	†	<i>S. aureus</i>			25,27
K	17	30/M	Q293X/Q293X	Canada	Alive	<i>S. pneumoniae</i>			25,27
K	18	30/M	Q293X/Q293X	Canada	Alive	<i>S. pneumoniae</i>		<i>M. avium</i>	25,27
L	19	2.5/M	118msA/118msA	Japan	†	<i>S. pneumoniae</i>			25,44
L	20	4/M	118msA/118msA	Japan	Alive	<i>S. pneumoniae</i>			25,44
M	21	4 mo/F	ND	USA	†			Undocumented meningitis	25
M	22	3/M	Q293X/620-621delAC	USA	Alive	<i>S. pneumoniae</i>			25
N	23	5/F	Y48X/631delG	Canada	Alive				25
O	24	19/M	1240insA/ 942-1481_1125+547del	Canada	Alive	<i>S. pneumoniae</i> , <i>S. aureus</i>			25
P	25	4 mo/F	ND	Australia	†	<i>S. pneumoniae</i>			25
P	26	6 mo/F	Q293X/Q293X	Australia	†	<i>S. pneumoniae</i> , <i>S. aureus</i>			25
Q	27	14/F	Q293X/Q293X	USA	Alive	<i>S. pneumoniae</i>			25
R	28	10/M	Q293X/Q293X	USA	Alive	<i>S. pneumoniae</i> , <i>S. aureus</i>	<i>P. aeruginosa</i>	<i>Enterovirus</i>	25,30

Kindred	P	Age/Sex (yr)	Mutation of MyD88*	Country of Origin	Outcome Status	Invasive Infections With Gram-Positive Bacteria	Invasive Infections With Gram-Negative Bacteria	Other	Ref.
N	29	2/M	Y48X/631delG	Canada	Alive				PR
S	30	4/F	M1V/1188+520A>G	Slovenia	Alive		<i>P. aeruginosa</i>		16
T	31	18/M	R12C/831+5G>T	France	Alive		<i>P. aeruginosa</i>		20
U	32	15 mo/M	Q293X/Q293X	UK	†				PR
U	33	6 mo/M	Q293X/Q293X	UK	Alive	<i>S. pneumoniae, S. aureus</i>			PR
V	34	6/F	Q293X/G298D	UK	Alive	<i>S. pneumoniae</i>			6
W	35	13/M	Y430X/1126-1 G>T	El Salvador	Alive			Bacterial infec.	23
W	36	4/F	Y430X/1126-1 G>T	El Salvador	Alive	<i>S. agalactiae, S. pneumoniae</i>	<i>S. sonnei</i>		23
X	37	14/F	Q293X/Q293X	UK	Alive	<i>S. pneumoniae, S. pyogenes</i>	<i>P. aeruginosa, H. influenzae type b</i>		6
Y	38	18 mo/M	Q293X/593delG	UK	†	<i>S. pneumoniae</i>	<i>P. aeruginosa</i>		6
Y	39	2/M	Q293X/593delG	UK	Alive				6
Z	40	6 mo/F	Q293X/Q293X	France	Alive		<i>P. aeruginosa</i>		PR
A1	41	14 mo/M	ND	UK	†		<i>P. aeruginosa</i>		PR
A1	42	4/F	Q293X/897_900delCAAT	UK	Alive	<i>S. pneumoniae</i>	<i>N. meningitidis</i>		PR
L	43	3/F	I18insA/118insA	Japan	Alive				PR
B1	44	2/M	I18insA/R183X	Japan	Alive				PR
C1	45	3/F	I18insA/118insA	Japan	†				PR
C1	46	9 mo/F	I18insA/118insA	Japan	†		<i>P. aeruginosa</i>		PR
D1	47	12 mo/F	Q293X/831+5G>T	USA	†				PR
E1	48	12/M	Q293X/Q293X	France	Alive	<i>S. pneumoniae</i>			PR

Kindred	P	Age/Sex (yr)	Mutation of MyD88*	Country of Origin	Outcome Status	Invasive Infections With Gram-Positive Bacteria	Invasive Infections With Gram-Negative Bacteria	Other	Ref.
a	1	11 mo/M	E65del/E65del	France	†	<i>S. pneumoniae</i>		Adenovirus Rotavirus	49
b	2	5/F	R209C/L106P	Turkey	Alive	<i>S. pneumoniae</i>			49
c	3	17/F	R209C/R209C	Portugal	Alive	<i>S. pneumoniae</i>	<i>Salmonella</i> spp.		49
c	4	11/M	R209C/R209C	Portugal	Alive	<i>S. pneumoniae, S. aureus, β-hemolytic Streptococci</i>	<i>S. enteritidis</i>		49
d	5	11 mo/F	E65del/E65del	Spain	†	<i>S. pneumoniae</i>		RSV	49
d	6	4/M	E65del/E65del	Spain	†	<i>S. pneumoniae, S. aureus</i>			49
d	7	2 mo/M	E65del/E65del	Spain	†	<i>S. pneumoniae</i>			49
e	8	8/M	E65del/E65del	Spain	Alive	<i>β-hemolytic Streptococci</i>			49
e	9	5/F	E65del/E65del	Spain	Alive	<i>S. pneumoniae, S. aureus</i>		<i>C. albicans</i>	49
a	10	2/F	E65del/E65del	France	†	<i>S. aureus, S. pneumoniae</i>	<i>H. influenzae type e</i>	<i>M. catarrhalis</i>	PR
f	11	5 mo/M	ND	Serbia	†		<i>P. aeruginosa</i>		PR
f	12	1/M	E65del/E65del	Serbia	Alive		<i>P. aeruginosa</i>		PR

Abbreviations: † = dead, ND = no data, P = patient, PR = present report, RSV = respiratory syncytial virus, UK = United Kingdom, USA = United States of America.
 *The mutation numbering has been adjusted from the original report (reference 49) to correspond to the dominant ATG initiation in the new reference sequence of GenBank (NM 001172567.1, GI 289546502).

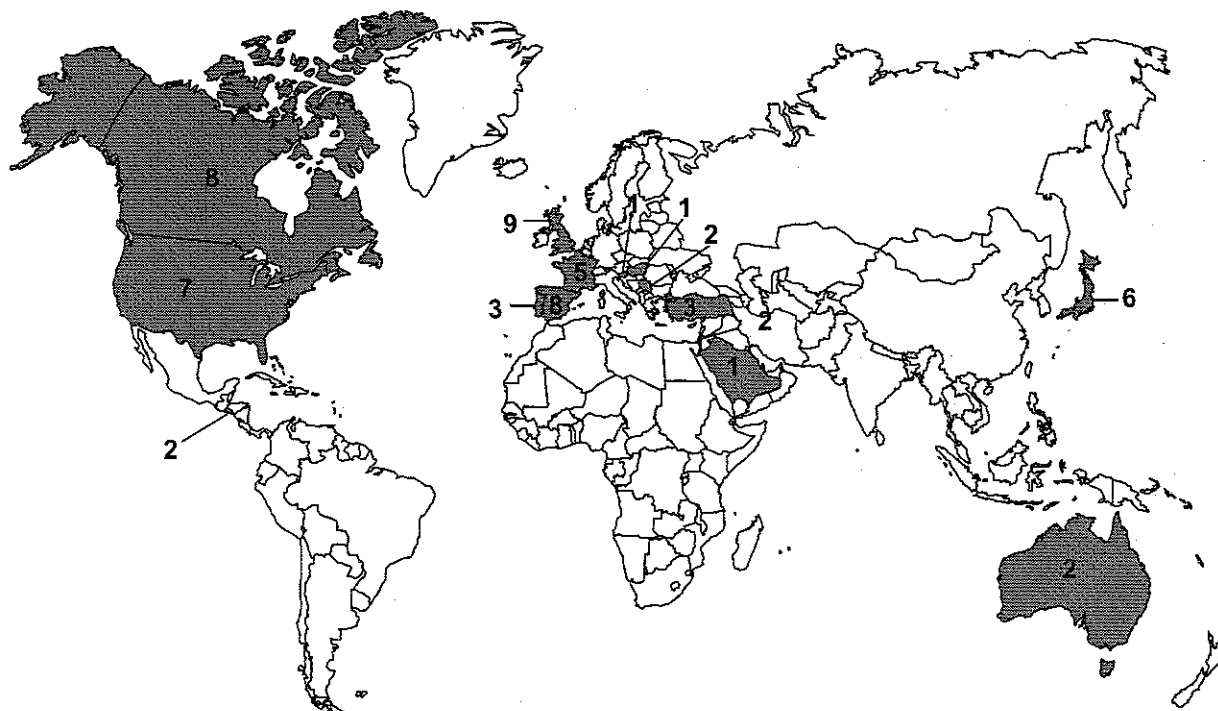

FIGURE 4. Countries of origin of the 31 kindreds with IRAK-4 deficiency and the 6 kindreds with MyD88 deficiency identified. The number of patients identified in each country is indicated.

Patients with MyD88 deficiency from 5 kindreds were homozygous, and 1 patient (b-P2) was compound heterozygous.⁴⁹ Two MyD88 mutant alleles were found to be associated with the production of very small amounts of a nonfunctional protein (E65del and L106P), whereas the R209C mutant allele was associated with the quantitatively normal production of a nonfunctional protein.⁴⁹ (The mutation numbering has been adjusted from the original report [reference 49] to correspond to the dominant ATG initiation in the new reference sequence of GenBank [NM 001172567.1, GI 289546502].)

Immunologic Investigations

We analyzed blood leukocyte subsets in 29 patients with IRAK-4 deficiency and 10 patients with MyD88 deficiency. We previously showed that monocyte and dendritic cell subsets were present in normal numbers in 3 patients with IRAK-4 deficiency.²⁵ T-cell subsets, including CD4 and CD8 T cells, were also present in normal numbers (24 patients with IRAK-4 deficiency and 6 with MyD88 deficiency tested) (Tables 2 and 3). T cells proliferated normally in response to the mitogen phytohemagglutinin, CD3-specific antibodies, and recall antigens *in vitro* (12 patients with IRAK-4 deficiency and 3 with MyD88 deficiency tested).

IgM, IgG, and IgA levels were normal for age in 15 IRAK-4-deficient and in 3 MyD88-deficient patients, and high in 12 IRAK-4-deficient and 4 MyD88-deficient patients. Among these patients, 5 patients with IRAK-4 deficiency and 2 with MyD88 deficiency had very high IgG4 levels. IgG level was low in 1 IRAK-4-deficient patient (U-P32) and 1 MyD88-deficient patient (d-P5). Two IRAK-4-deficient patients had high levels of IgM (I-P13, V-P34). In particular, IgE levels were high in 14 IRAK-4-deficient patients and in 3 MyD88-deficient patients, with a total of 26 patients evaluated (Tables 4–6). The highest IgE-levels in IRAK-4- and MyD88-deficient patients were, how-

ever, not as high as those in patients with STAT3 or DOCK8 deficiency, with the exception of 1 patient with IRAK-4 deficiency (A-P1).^{34,53} Antibody responses to protein antigens (tetanus toxoid, poliovirus and/or diphtheria) were normal in the 17 IRAK-4-deficient and 2 MyD88-deficient patients tested. Six of the 13 IRAK-4-deficient (A-P1, F-P7, J-P15, O-P24, S-P30, V-P34) and all 5 MyD88-deficient (b-P2, c-P3, c-P4, e-P9, a-P10) patients tested had detectable IgG antibodies against pneumococcus after infection and/or immunization with conjugate or nonconjugate vaccines. The antibody response (serotypes 3, 4, 6B, 9N, 14, 18C, 19F) to glycans following nonconjugated pneumococcal vaccine was impaired in 5 (B-P2, G-P8, K-P17, K-P18, R-P28) of the 9 IRAK-4-deficient patients explored. Three IRAK-4-deficient patients (H-P10, O-P24, W-P36) received conjugated and nonconjugated pneumococcal vaccine, and the response to vaccination was in the normal range in 2 of these patients (O-P24, W-P36), at least at the time points 1 and 5 months after the last booster vaccination. One IRAK-4-deficient patient (S-P30) received only conjugated pneumococcal vaccine, and the response to immunization was normal. Unfortunately, we found no correlation between the presence or absence of antipneumococcal antibodies and the occurrence of invasive pneumococcal disease. The antibody response to conjugated *H. influenzae* type b vaccine was normal in the 13 IRAK-4-deficient patients and 1 MyD88-deficient patient explored. One IRAK-4-deficient patient (X-P37) who developed meningitis caused by *H. influenzae* type b had antibodies against *H. influenzae* type b after infection. The production of IgM allo-hemagglutinins directed against erythrocyte AB antigens was impaired in 3 of the 10 IRAK-4-deficient and in 1 of the 3 MyD88-deficient patients explored (Tables 4–6).

Finally, the counts of CD16-positive and CD56-positive NK cells were normal in the 19 IRAK-4-deficient and 6 MyD88-deficient patients tested (Tables 2 and 3). There thus seemed to

TABLE 2. Immunologic Investigation: Blood Lymphocyte Subsets and T-Cell Proliferation in IRAK-4-Deficient Patients*

Patients	Normal Values																			Normal Values												
	P40	P26	P46	P10	P23	P30	P38	P43	P11	P19	P36	P13	P34	P37	P1	P15	P28	P8	P3		P31	P24	P2	P2	P17	P18						
(age)	3 mo	6 mo	9 mo	1 yr	1 yr	1 yr	1 yr	1 yr	2 yr	2 yr	3 mo-2 yr	3 yr	4 yr	4 yr	4 yr	5 yr	5 yr	5 yr	6 yr	7 yr	7 yr	11 yr	13 yr	14 yr	14 yr	27 yr	27 yr	Adult				
Lymph., 10 ⁹ /μL	7.5	4.2		5.97	6.2	5.2	5.25	6.38	5.0	5.0	(3.4-9)	2.95	2.8	3.6	3.82	3.3	4.8	3.2	1.9	(2.3-5.4)	5.0	2.4	2.1	2.6	(1.9-3.7)	1.3	1.3	(1.4-3.3)				
T cells, %	68	62	59	77	66	45	77	71	73	71	(53-84)	79	58	63	60	75	86	57	73	(56-75)	68	85	76	75	(56-84)	72	76	(63-84)				
CD4	42	35	36	45	48	50	33	57	48	48	(31-64)	49	35	39	33	55	63	35	46	(28-47)	52	48	48	54	(31-52)	56	46	(34-62)				
CD8	24	21	29	11	26	14	10	18	29	29	(12-30)	29	19	19	27	32	19	24	22	(16-30)	14	28	24	22	(18-35)	13	20	(14-41)				
CD45RA/CD4											(64-95)																					
CD45RO/CD4											(4-18)	6	20	9	8	3	3	5	5	(4-17)	2	13	2	12	(3-22)	11	8	(5-20)				
NK cells, %	12	15		5	12	7	8		7	17	(6-41)	13	19	27	26	23	6	38	18	(14-33)	28	10	10	16	(6-23)	15	12	(6-17)				
B cells, %	18	22		34	10	20	45	14	7	17																						
Prolif. × 10 ³ cpm																																
CD3											(>30)																					
PHA											(>50)																					
PPD											(>10)																					
Candidin											(>10)																					
Tetanus											(>10)																					
<i>S. aureus</i>											(>10)																					

*Data given as total lymphocyte counts and percentages of T cells, NK cells, and B cells. Age-specific normal values are shown in parentheses. Proliferative responses to OKT3 (50 ng/mL) ("CD3"), the mitogen PHA, and various antigens (PPD, candidin, tetanus) are listed.

TABLE 3. Immunologic Investigation: Blood Lymphocyte Subsets and T-Cell Proliferation in MyD88-Deficient Patients*

Patients	P1	P10	P2	Normal Values	P6	P9	Normal Values	P8	P4	Normal Values
(age)	10 mo	15 mo	2 yr	3 mo–2 yr	2.5 yr	3 yr	2–6 yr	7 yr	8 yr	6–12 yr
Lymph., 10 ⁹ /μL		5.5	2.4	(3.4–9)		3.32	(2.3–5.4)	2.43		(1.9–3.7)
T cells, %										
CD3		69	64	(53–84)	68	64	(56–76)	47	77	(60–76)
CD4		39	39	(31–64)	35	39	(28–47)	25	43	(31–47)
CD8		22	27	(12–30)	33	25	(16–30)	22	27	(18–35)
CD45RA/CD4		79		(64–95)			(53–86)		46	(46–77)
CD45RO/CD4		25							59	
NK cells, %		5	20	(4–18)	7	11.5	(4–17)	26	4	(4–17)
B cells, %	27	24	18	(6–41)	23	17.5	(14–33)	17	18	(13–27)
Prolif. × 10 ³ cpm										
CD3			46	(>30)					56	(>30)
PHA			175.5	(>50)	50				113	(>50)
PPD			4.2	(>10)					10.3	(>10)
Candidin			1.0	(>10)					15.2	(>10)
Tetanus			26.0	(>10)					21	(>10)

*Data given as total lymphocyte counts and percentages of T cells, NK cells, and B cells. Age-specific normal values are shown in parentheses. Proliferative responses to OKT3 (50 ng/mL) (“CD3”), the mitogen PHA, and various antigens (PPD, candidin, tetanus) are listed.

be no overt defect of leukocyte development in IRAK-4- and MyD88-deficient patients. Antigen-specific T- and B-cell responses seemed to be normal, as detected with these routine immunologic evaluations, with 2 notable exceptions. First, the glycan-specific IgG and IgM antibody response against at least pneumococcal and AB glycans was impaired in half of the patients tested. Second, serum IgG4 and IgE levels were high in up to 35% (n = 7/20) and 65% (n = 17/26), respectively, of the patients tested (both were high in 4 patients). Nevertheless, none of the MyD88- and IRAK-4-deficient patients in this cohort suffered from allergic asthma, and a chronic eczematous skin disease was reported only in patient F-7. A survey is underway to assess laboratory and clinical manifestation of allergy in patients

with MyD88 and IRAK-4 deficiency (Gallego and Picard, unpublished data).

Invasive Bacterial Infections

Invasive bacterial disease (InvBD) is defined here as clinical disease due to the presence of a disease-causing bacterium in a normally sterile fluid or tissue. There were 114 reported episodes of InvBD in 48 IRAK-4-deficient patients (n = 2.38 episodes per patient; range, 0–10), including meningitis (47 episodes, 41.2% of all invasive episodes), sepsis (including bacteremia, septicemia, and shock; 26 episodes, 22.8%), arthritis (17 episodes, 14.9%), osteomyelitis (7 episodes, 6.1%), and deep inner organ/tissue abscesses (17 episodes, 14.9%) (Figure 5). Deep-seated

TABLE 4. Immunologic Investigation: Ig Levels and Humoral Responses to Recall Antigens and to Glycans in IRAK-4-Deficient Patients*

Patients	P6	P22	P40	P26	P46	Normal Values	P5	P10	P23	P30	P32	P38	P43	P11	P39	Normal Values
(age)	2 mo	3 mo	3 mo	6 mo	9 mo	(3–9 mo)	1 yr	1 yr	1 yr	1 yr	1 yr	1 yr	1 yr	2 yr	2 yr	(1–3 yr)
Serum Ig (g/L)																
IgG	5.7	2.45	7.38	5.68	3.84	(2.35–5.49)	5.4	11.4	8.9	16.9	2.21	4.55	13.8	17	6.31	(3.35–8.96)
IgG1					1.37	NA		7.2		13.05			8.17			(>3)
IgG2					0.30	NA		1.26		2.09			2.01			(>0.30)
IgG3					0.07	NA		0.20		0.68			0.9			(>0.12)
IgG4					0.03	NA		0.28		0.41			<0.3			(<1)
IgA	0.6	0.16	0.25	0.14	0.3	(0.12–0.62)	0.2	0.34	0.47	1.09	0.26	0.34	0.86	0.9	0.25	(0.27–1.22)
IgM	0.6	0.51	0.63	0.40	0.33	(0.34–0.95)	1.1	1.02	1.11	0.98	0.43	0.33	2.27	2.0	0.52	(0.58–1.53)
IgE (kU/L)				19	203	(<15)		129	801	257		13.8	38.2	198		(<40)
Specific antibodies																
Antitetanus				0.21		(>0.1 IU/mL)			0.12	1.15		0.32		>0.1		(>0.1 IU/mL)
Poliovirus						(>40)										(>40)
Diphtheria				0.12		(>0.1 IU/mL)			0.26	0.7						(>0.1 IU/mL)
<i>S. pneumoniae</i>						(>0.3 μg/mL)			<0.3	2.04						(>0.3 μg/mL)
<i>H. influenzae</i> b				0.31		(>0.15 μg/mL)			>9	0.56	0.16					(>0.15 μg/mL)
Ailohemagglutinin						NA								1/16		(>1/8)

*Serum immunoglobulin levels and titers for specific antibodies. Age-specific normal values are shown in parentheses.

abscesses affected the brain (3 episodes), peritoneum (8 episodes), liver (4 episodes), and muscles (2 episodes: subfascial calf and psoas abscesses).

There were 33 reported episodes of InvBD in 12 MyD88-deficient patients (n = 2.75 episodes per patient; range, 1–7), including meningitis (17 episodes, 51.5% of all invasive episodes), sepsis (4 episodes, 12.1%), arthritis (6 episodes, 18.2%), osteomyelitis (2 episodes, 6.1%), and deep inner organ/tissue abscesses (4 episodes, 12.1%).

Five IRAK-4-deficient patients never developed InvBD, 4 of whom were diagnosed at birth and remained asymptomatic on prophylactic treatment (Figure 2; Table 1). The remaining patient without InvBD was diagnosed at the age of 2 years following an episode of *Staph. aureus* adenitis (N-P23) and received prophylactic treatment from that time to the end of follow-up. All the MyD88-deficient patients reported have presented InvBD (Figure 5; Table 1). Neurologic complications secondary to meningitis and brain abscesses occurred in 7 IRAK-4-deficient patients; 5 of them developed secondary deafness (K-P17, Q-P27, R-P28, W-P35, X-P37), and 2 other patients developed hemiplegia (B-P2) or developmental delay (M-P22). Three MyD88-deficient patients (c-P3, c-P4, e-P9) developed secondary deafness. The overall frequency and the sites of InvBD were found to be indistinguishable in IRAK-4-deficient and MyD88-deficient patients.

Noninvasive Bacterial Infections

Noninvasive bacterial disease (NInvBD) most frequently presented as skin infections, such as recurrent localized cellulitis, furunculosis, and folliculitis, often prompting intravenous and prolonged antibiotic treatment (in 21 of 48 IRAK-4-deficient and 3 MyD88-deficient patients) (Figure 6). IRAK-4-deficient patients also presented with adenitis (14 patients), omphalitis (6 patients), maxillary sinusitis (6 patients), tonsillar abscesses (4 patients), necrotizing epiglottitis (1 patient), necrotizing pharyngitis (1 patient), necrotizing palate infection (1 patient), recurrent otitis media (12 patients), and orbital cellulitis or endophthalmitis (6 patients). MyD88-deficient patients developed adenitis (5 patients), sinusitis (2 patients, a-P1 and c-P3), recurrent otitis

media (2 patients), gingivitis and periodontal disease (1 patient, c-P3). Intriguingly, only 21 episodes of pneumonia were reported, in only 9 IRAK4-deficient patients and 2 MyD88-deficient patients. There were no episodes of acute bronchitis and no chronic bronchopulmonary disease. Acute upper urinary tract infections were found in only 2 IRAK-4-deficient patients and 1 MyD88-deficient patient. Most NInvBD in MyD88-deficient and IRAK-4-deficient patients affected the skin and the upper respiratory tract—sites at which necrotizing infections are particularly common.

Documented Bacterial Infections

In both IRAK-4 and MyD88 deficiency, *Str. pneumoniae*, *Staph. aureus*, and *P. aeruginosa* were, by far, the most commonly isolated pathogens causing InvBD and NInvBD (Figure 7; Table 1). In IRAK-4-deficient patients, *Str. pneumoniae* accounted for 40.1% (67/167), *Staph. aureus* for 25.1% (42/167), and *P. aeruginosa* for 19.7% (33/167) of all documented bacterial infections (a total of 84.9%). *Str. pneumoniae* was involved in 54.3% (57/105) of InvBD episodes, whereas *Staph. aureus* and *P. aeruginosa* were found in 14.3% (15/105) and 18% (19/105) of such episodes, respectively, accounting together for 87% of all cases of InvBD. The other bacteria causing invasive disease were *Streptococcus* species, *Shigella sonnei*, *Neisseria meningitidis*, *H. influenzae* type b, and *Clostridium septicum* (Table 1). In cases of NInvBD, the principal bacterium isolated was *Staph. aureus*, which was implicated in 43.5% (27/62) of documented episodes of NInvBD, whereas *P. aeruginosa* and *Str. pneumoniae* were found in 22.6% (14/62) and 16.1% (10/62), respectively. These 3 bacteria altogether accounting for 82% of all episodes of NInvBD.

In patients with MyD88 deficiency, *Str. pneumoniae* accounted for 37.5% (18/48), *Staph. aureus* for 31.2% (15/48), and *P. aeruginosa* for 12.5% (6/48) of all bacterial infections (81%) (Figure 7). *Str. pneumoniae* caused InvBD in 45.5% of cases (15/33), whereas *Staph. aureus* and *P. aeruginosa* were involved in 21.2% (7/33) and 12.1% (4/33) of the episodes, respectively (78.8% of all cases of InvBD). The other pathogens identified during invasive infections were β -hemolytic *Streptococci*, *Salmonella enteritidis*, *H. influenzae* type e, and

P36	P13	P37	P1	P15	P28	P34	P8	P3	Normal Values	P31	P24	P2	P17	P18	P7	Normal Values
3 yr	4 yr	4 yr	5 yr	5 yr	5 yr	5 yr	6 yr	7 yr	(3–7 yr)	11 yr	13 yr	14 yr	27 yr	27 yr	32 yr	(11 yr-adult)
11.2	13.6	9.29	11.7	10.3	18.99	11.1	13.6		(5.49–11.54)	12.8	7.6	14.4	15	13	16.7	(6.55–12.78)
8.82	10.2		6.85	6.88	8.44		8.41		(>4)	10.6	7.16	8.62				(>4)
0.65	2.63		0.4	1.18	5.37		3.12		(>0.40)	2.5	0.95	0.71				(>0.60)
0.36	0.13		0.19	0.45	0.29		0.34		(>0.16)	0.72	0.38	0.47				(>0.17)
0.29	1.85		1.41	0.5	4.89		3.54		(<1)	0.65	0.06	1.46				(<1)
1.19	0.64	0.57	0.63	1.31	1.51	0.6	2.42		(0.41–1.57)	1.02	0.49	0.88	0.3	0.6	1.1	(0.70–3.44)
1.59	1.65	0.85	0.72	0.50	0.96	3.5	0.52		(0.54–1.55)	1.38	1.91	0.64	1.3	1.5	1.9	(0.50–2.09)
6	977	106	17,400	356			187		(<60)	180	36.6	11	255	96.5	400	(<150)
0.58	>10			0.06	0.26	0.47	0.59	1.81	(>0.1 IU/mL)		0.47	0.47	0.34	0.46	0.06	(>0.1 IU/mL)
				>40					(>40)			40				(>40)
0.55			2.04	0.002			0.10	0.88	(>0.1 IU/mL)		0.72				0.18	(>0.1 IU/mL)
	0.2		1.9	>0.6	<0.3	>0.3	<0.3		(>0.3 μ g/mL)		3.59	<0.3	<0.3	<0.3	>0.3	(>0.3 μ g/mL)
>1	5.1	0.84	>1		1.98	12.3	>1	>1	(>0.15 μ g/mL)			>1			1.36	(>0.15 μ g/mL)
	1/8	1/1	1/128	1/16			1/2		(>1/16)		1/32		1/16	1/16	1/2	(>1/16)

TABLE 5. Immunologic Investigation: Ig Levels and Humoral Responses to Recall Antigens and to Glycans in MyD88-Deficient Patients*

Patients	P5	P10	Normal Values	P2	P6	P9	Normal Values	P8	P4	Normal Values	P3	Normal Values
(age)	8 mo	15 mo	(6-15 mo)	2 yr	2.5 yr	3 yr	(2-4 yr)	7 yr	8 yr	(5-8 yr)	15 yr	(14 yr-adult)
Serum Ig (g/L)												
IgG	2.23	6.2	(2.35-6.23)	12.4	13.6	29.2	(4.82-8.96)	12.5	8.31	(5.49-11.54)	12.5	(6.55-12.78)
IgG1		5.0	NA	10.3	10.36	20.4	(>4)	8.0	6.61	(>4)	9.8	(>4)
IgG2		0.88	NA	0.148	2.52	5.19	(>0.3)	3.2	0.96	(>0.40)	0.85	(>0.6)
IgG3		0.78	NA	0.59	0.3	1.7	(>0.15)	0.47	0.24	(>0.16)	0.56	(>0.17)
IgG4		0.07	NA	0.44	0.4	3.51	(<1)	3.7	0.1	(<1)	0.84	(<1)
IgA	0.36	0.52	(0.12-0.62)	0.5	0.32	1.6	(0.33-1.22)	1.32	1.21	(0.41-1.57)	1.36	(0.70-3.44)
IgM	0.41	0.93	(0.34-1.1)	1.59	0.61	1.24	(0.50-1.53)	0.29	0.9	(0.54-1.55)	0.69	(0.50-2.09)
IgE (U/mL)	53		(<30)	24.5	115	34	(<40)		199	(<60)	10.4	(<150)
Specific antibodies												
Antitetanus			(>0.1 IU/mL)			0.9	(>0.1 IU/mL)		1.3	(>0.1 IU/mL)		(>0.1 IU/mL)
<i>S. pneumoniae</i>		0.9	(>0.3 µg/mL)	17.96		11.5	(>0.3 µg/mL)		2.74	(>0.3 µg/mL)	3.85	(>0.3 µg/mL)
<i>H. influenzae</i> b			(>0.15 µg/mL)			3.4	(>0.15 µg/mL)			(>0.15 µg/mL)		(>0.15 µg/mL)
Allohemagglutinin			NA	1/4			(>1/8)		1/16		1/16	(>1/16)

*Serum immunoglobulin levels and titers for specific antibodies. Age-specific normal values are shown in parentheses.

Moraxella catarrhalis. In cases of NInvBD, the principal bacterium isolated was *Staph. aureus*, which was implicated in 53.3% (8/15) of NInvBD episodes, whereas *Str. pneumoniae* was found in 20% (3/15) and *P. aeruginosa* in 13.3% (2/15) of NInvBD episodes. These 3 bacteria accounting altogether for 86% of all cases of NInvBD.

In summary, in both IRAK-4 and MyD88 deficiencies, *Str. pneumoniae*, *Staph. aureus*, and *P. aeruginosa* were by far the most commonly isolated pathogens causing InvBD (52.2%, 15.9%, and 16.7% of cases, respectively), and *Staph. aureus* was by far the most commonly isolated pathogen causing NInvBD (45.5%) (Figure 7).

Other Infections

Among infections caused by agents other than pyogenic bacteria, there were no severe mycobacterial, viral, parasitic, and fungal diseases. One IRAK-4-deficient patient (K-P18) had a *Mycobacterium avium* lung infection and otitis at the age of 15 years. Nine patients (8 IRAK-4-deficient patients and 1 MyD88-deficient patient) received Bacille Calmette-Guérin (BCG) vaccination without adverse effect. One IRAK-4-deficient patient (R-P28) had *Staph. aureus* meningitis at the age of 6 years, and *Enterovirus* was isolated from the cerebral spinal fluid by polymerase chain reaction. Another IRAK-4-deficient patient (C-P3) had an episode of diarrhea caused by *Enterovirus* at the age of 7 years. One MyD88-deficient patient (a-P1) experienced 2 hospital-acquired episodes of diarrhea caused by adenovirus and rotavirus, with both infections following a normal course during the first year of life. One MyD88-deficient patient (d-P5) had 3 episodes of respiratory syncytial virus bronchitis at 2, 3, and 4 months of age, with a spontaneous favorable outcome. One IRAK-4-deficient patient (T-P31) developed localized warts at the age of 16 years. One MyD88-deficient patient (d-P6) developed chickenpox 10 days after varicella zoster virus vaccination. Several IRAK-4- and MyD88-deficient patients had humoral responses to viruses and *Toxoplasma gondii* without abnormal clinical manifestations (Table 7). Two IRAK-4-deficient patients (C-P3, W-P36) and 2 MyD88-deficient patients (c-P4, e-P9) had oral thrush, even in the absence of antibiotic treatment. Finally, *Curvularia* species were isolated from the maxillary sinus of 1 IRAK-4-deficient patient (C-P3) living in the southern United States.

In conclusion, it is noteworthy that IRAK-4-deficient and MyD88-deficient patients were not particularly susceptible to most other microorganisms, including common viruses (for example, herpes viruses, enteroviruses, adenoviruses, and papillomaviruses), and widespread bacteria (for example, *Listeria* and *Mycobacterium*), parasites (for example, *Toxoplasma*), and fungi (for example, *Cryptococcus*, *Pneumocystis*, *Candida*, and *Aspergillus*).

Patient Outcome

Most IRAK-4-deficient patients had their first bacterial infection early in life, before the age of 2 years in 87.5% (n = 42) of cases. The first InvBD occurred before the age of 2 years in 79.2% (n = 38), and the first NInvBD in 48% (n = 23) of these patients. The first bacterial infection occurred before the age of 6 months in 54% (n = 26) of IRAK-4-deficient patients. The first InvBD occurred before the age of 6 months in 35.4% (n = 17), and the first NInvBD in 37.5% (n = 18) of these patients. The first bacterial infection even occurred during the neonatal period in 31.2% (n = 15) of IRAK-4-deficient patients. The first InvBD occurred during the neonatal period in 14.5% (n = 7) and the first NInvBD in 27% (n = 13) of these patients (5 patients had both InvBD and NInvBD in the neonatal period) (Figures 8 and 9).

TABLE 6. Immunologic Investigation Summary

	IRAK-4-Deficient Patients	MyD88-Deficient Patients
T lymphocytes subset		
Normal pts/tested pts (%)	24/24 (100)	6/6 (100)
B lymphocytes subset		
Normal pts/tested pts (%)	23/23 (100)	7/7 (100)
NK lymphocytes subset		
Normal pts/tested pts (%)	19/19 (100)	6/6 (100)
T cell proliferation		
Normal pts/tested pts (%)	12/12 (100)	3/3 (100)
IgG levels		
Normal pts/tested pts (%)	15/28 (53.6)	3/8 (37.5)
Pts with increased level/tested pts (%)	12/28 (42.9)	4/8 (50)
Pts with decreased level/tested pts (%)	1/28 (3.6)	1/8 (12.5)
IgG1,2,3 levels		
Normal pts/tested pts (%)	13/13 (100)	7/7 (100)
IgG4 levels		
Normal pts/tested pts (%)	8/13 (61.5)	5/7 (71.4)
Pts with increased level/tested pts (%)	5/13 (38.5)	2/7 (28.6)
IgA levels		
Normal pts/tested pts (%)	25/28 (89.3)	7/8 (87.5)
Pts with decreased level/tested pts (%)	3/28 (10.7)	—
Pts with decreased level/tested pts (%)	—	1/8 (12.5)
IgM levels		
Normal pts/tested pts (%)	26/28 (92.9)	6/8 (75)
Pts with increased level/tested pts (%)	2/28 (7.1)	1/8 (12.5)
Pts with decreased level/tested pts (%)	—	1/8 (12.5)
IgE levels		
Normal pts/tested pts (%)	6/20 (30)	3/6 (50)
Pts with increased level/tested pts (%)	14/20 (70)	3/6 (50)
Specific Ab to protein antigens (tetanus, diphtheria, or polio)		
Normal pts/tested pts (%)	17/17 (100)	2/2 (100)
Ab against <i>H. influenzae</i>		
Normal pts/tested pts (%)	14/14 (100)	1/1 (100)
Ab against <i>S. pneumoniae</i>		
Normal pts/tested pts (%)	6/13 (46.2)	5/5 (100)
Pts with abnormal response/tested pts (%)	7/13 (53.8)	
Ab production after immunization with PNCV23		
Normal pts/tested pts (%)	4/9 (44.4)	
Pts with abnormal response/tested pts (%)	5/9 (55.6)	
Ab production after immunization with PNCV23+PCV7		
Normal pts/tested pts (%)	2/3 (66.7)	
Pts with abnormal response/tested pts (%)	1/3 (33.3)	
Ab production after immunization with PCV7		
Normal pts/tested pts (%)	1/1 (100)	
Allohemagglutinin		
Normal pts/tested pts (%)	7/10 (70)	3/3 (100)
Pts with decreased level/tested pts (%)	3/10 (30)	

Abbreviations: Ab = antibody, PCV7 = 7 valent conjugate vaccine, PNCV23 = 23 valent nonconjugate vaccine, pts = patients.

Similarly, bacterial infections occurred early in most MyD88-deficient patients, before the age of 2 years in 91.7% (n = 11) of these patients. The first InvBD occurred before the age of 2 years in 50% (n = 6), and the first NInvBD in 66.7% (n = 8) of these patients. The first bacterial infection occurred before the age of 6 months in 91.7% (n = 11) of MyD88-deficient patients. The first InvBD occurred before the age of 6 months in 50% (n = 6), and

the first NInvBD in 66.7% (n = 8) of the cases. The first bacterial infection occurred in the neonatal period in 33.3% (n = 4) of MyD88-deficient patients. The first InvBD occurred during the neonatal period in 16.7% (n = 2), and NInvBD in 16.7% (n = 2) of these patients (Figures 8 and 9).

IRAK-4-deficient patients presented no InvBD from the age of 14 years on (a total of 10 patients, aged 14, 15, 17, 18, 19, 27,

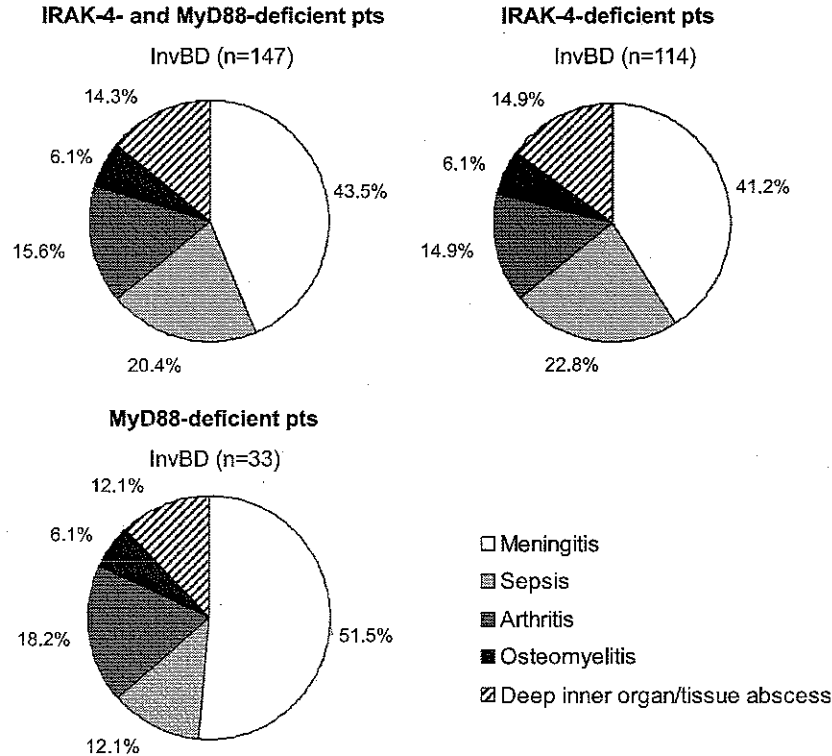

FIGURE 5. Invasive bacterial infections (episodes): in all patients, in IRAK-4-deficient patients, and in MyD88-deficient patients.

30, and 35 years), but the oldest patient, who was aged 35 years, still suffered from occasional skin infections at last follow-up (Figures 8 and 9). MyD88-deficient patients presented no InvBD from the age of 11 years on (2 patients aged 11 and 17 years), but the oldest patient, aged 17 years, still suffered from NInvBD at last follow-up. InvBD was recurrent (2–10 episodes) in 33 of the IRAK-4-deficient patients. In 3 IRAK-4-deficient patients, 2–3 recurrences of invasive pneumococcal disease due to the

same serotype (6A, 14, or 19F) were identified at intervals of 1–24 months. InvBD was recurrent (2–7 episodes) in 5 of the MyD88-deficient patients. There were 114 reported episodes of InvBD in 48 IRAK-4-deficient patients (n = 2.38 episodes per patient; range, 0–10), and 33 reported episodes of InvBD in 12 MyD88-deficient patients (n = 2.75 episodes per patient; range, 1–7). Finally, 24 patients died of InvBD (18/48 IRAK-4, 6/12 MyD88), all before the age of 8 years, and most before the age

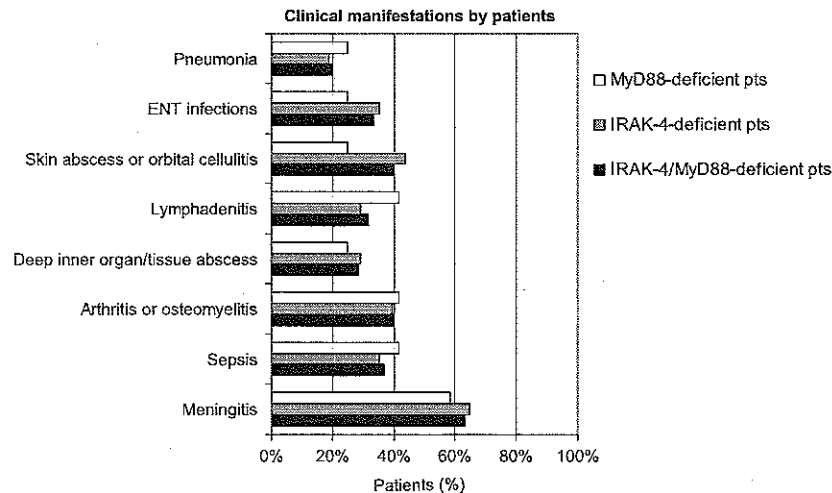

FIGURE 6. Percentage of clinical manifestations found in each patient: in MyD88-deficient patients, in IRAK-4-deficient patients, and in all patients. (ENT = ear, nose, and throat.)

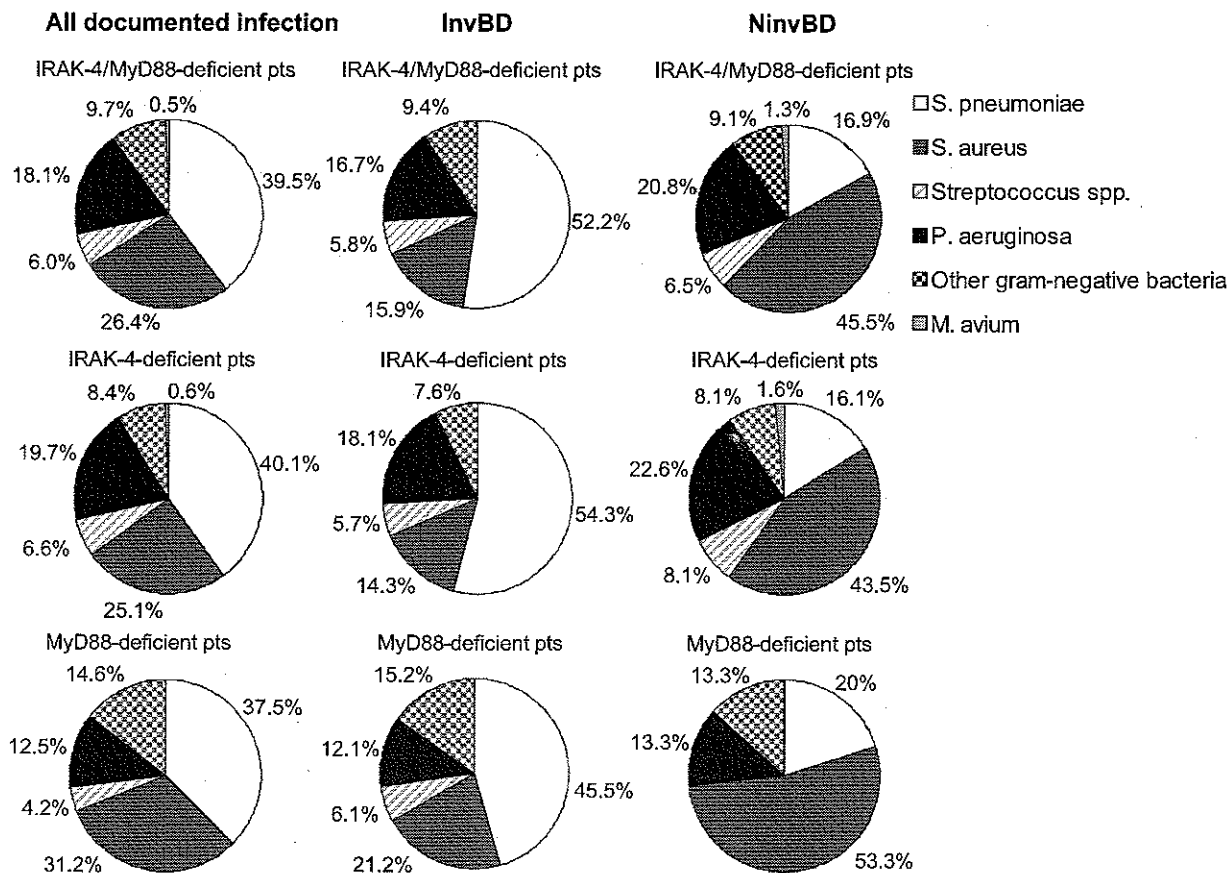

FIGURE 7. Overview of pathogens isolated during bacterial infections of IRAK-4-deficient and MyD88-deficient patients. **Left column,** overview of all pathogens isolated (all documented infection). In IRAK-4-deficient patients: other *Streptococcus* species (*Str. agalactiae*, *Str. equis*, *Str. intermedius*, *Str. milleri*, *Str. pyogenes*, and *Str. parasanguis*), other gram-negative bacteria (*Shigella sonnei*, *Neisseria meningitidis*, *Serratia marcescens*, *Moraxella catarrhalis*, *Clostridium septicum*, *Haemophilus influenzae* type b, *Citrobacter freundii*, and *Escherichia coli*), and *Mycobacterium avium*. In MyD88-deficient patients: other *Streptococcus* species (β -hemolytic *Streptococci*) and other gram-negative bacteria (*Salmonella enteritidis*, *Haemophilus influenzae* type e, *Moraxella catarrhalis*, *Klebsiella pneumoniae*, and *E. coli*). **Center column,** pathogens isolated during invasive bacterial infections (InvBD) (meningitis, sepsis, arthritis, osteomyelitis, and deep abscesses). In IRAK-4-deficient patients: other *Streptococcus* species (*Str. agalactiae*, *Str. milleri*, *Str. pyogenes*, and *Str. parasanguis*) and other gram-negative bacteria (*Shigella sonnei*, *N. meningitidis*, *Serratia marcescens*, *H. influenzae* type b and *C. septicum*). In MyD88-deficient patients: other *Streptococcus* species (β -hemolytic *Streptococci*) and other gram-negative bacteria (*Salmonella enteritidis*, *Haemophilus influenzae* type e, and *Moraxella catarrhalis*). **Right column,** pathogens isolated during noninvasive bacterial infections (NinvBD). In IRAK-4-deficient patients: other *Streptococcus* species (*Str. equis*, *Str. intermedius*, *Str. pyogenes*) and other gram-negative bacteria (*Serratia marcescens*, *Moraxella catarrhalis*, *C. septicum*, *Citrobacter freundii*, and *E. coli*), and *M. avium*. In MyD88-deficient patients: other *Streptococcus* species (β -hemolytic *Streptococci*) and other gram-negative bacteria (*K. pneumoniae* and *E. coli*).

of 2 years (n = 17) (Figure 10; Table 1). Sixteen of these patients died of invasive pneumococcal disease (11 IRAK-4-deficient and 5 MyD88-deficient patients).

Inflammatory Response

Impaired ability to mount inflammation during invasive infections has been previously described in isolated case reports and smaller series.^{12,18,25,46} In the current study we evaluated temperature, C-reactive protein (CRP) levels, total leukocyte counts, and neutrophil counts in invasive infections during 3 periods of life that are known to have different levels of inflammatory responses: the neonatal period (day 1 to day 28), infancy (day 29 to 1 year), and childhood (children aged >1 year). In analyses carried out on admission to the hospital, we often observed inflammatory signs within the normal range, despite infection (Figures 11–13; Tables 8 and 9). Little (n = 3) or no (n = 2) increase in body

temperature above 37°C was observed in neonates with IRAK-4-deficiency. By contrast, a significant increase in CRP concentration (>10 mg/L) was observed in all neonates with IRAK-4 deficiency and InvBD. Counts of total leukocytes and of neutrophils remained low despite InvBD; none of the neonates showed neutrophil counts above the 95th percentile adjusted for age.²⁹ Initial temperature on admission was below 38°C in 10 of the 23 cases of InvBD in infants and in 22 of the 44 cases of InvBD in children admitted. Similarly, initial CRP concentration was below 10 mg/L in 12 of 23 cases of InvBD in infancy and in 16 of 36 cases of InvBD in childhood. Despite the presence of InvBD, total leukocyte counts remained below 14,000/ μ L in 21 of 35 episodes in infancy and in 46 of 52 episodes in childhood. One frequently documented abnormality was a neutrophil count below 6000/ μ L, observed in 20 of 26 episodes in infancy and 30 of 47 InvBD episodes in childhood.

TABLE 7. Humoral Responses to Viruses and *Toxoplasma gondii*

	IRAK-4-Deficient Patients	MyD88-Deficient Patients
	(Positive pts/Tested pts)	(Positive pts/Tested pts)
Herpes simplex virus	0/8	2/4
Varicella zoster virus	5/9	2/3
Cytomegalovirus	2/9	3/4
Epstein-Barr virus	4/8	3/5
HHV6	6/6	Not done
HHV8	0/2	Not done
Parvovirus B 19	2/6	Not done
Rubella	5/6	4/4
Measles	Not done	3/4
Mumps	5/6	2/3
Coxsackie virus B1,2,3,4,6	6/7	Not done
RSV	6/6	Not done
Human metapneumovirus	5/6	Not done
Rotavirus	Not done	1/1
Adenovirus	Not done	1/1
HIV	0/3	Not done
VDRL	0/1	Not done
Toxoplasma	0/3	1/3

Abbreviations: See previous tables. HHV = human herpes virus, HIV = human immunodeficiency virus, VDRL = Venereal Disease Research Laboratory test.

Thus, both MyD88 and IRAK-4 deficiencies confer a predisposition to severe InvBD impairment of the ability to increase plasma CRP concentrations and mount fever. However, patients with IRAK-4 and MyD88 deficiency and InvBD may also present with high temperature and high levels of CRP, total leukocytes, and neutrophils (Figures 11–13). Pus formation was observed in the liver, joints, lymph nodes, saliva glands, and in the meninges, as well as in skin infections. Finally, separation of the umbilical cord later than 28 days after birth was observed in 10 IRAK-4-deficient patients.

Prophylaxis of Infections

Thirty-six patients with IRAK-4 deficiency or MyD88 deficiency received prophylaxis following diagnosis of the corresponding primary immunodeficiency, a diagnosis that occurred after 1 episode of InvBD in 30 patients (24 IRAK-4-deficient and 6 MyD88-deficient) and before any InvBD episode in 6 IRAK-4-deficient patients. Prophylactic treatment was discontinued in 7 (6 IRAK-4-deficient and 1 MyD88-deficient) of the 11 patients who reached the age of 14 years, and was continued in all others.

Preventive treatment included antibiotic prophylaxis (oral penicillin and/or cotrimoxazole in most cases (Table 10) in 28 IRAK-4-deficient and 6 MyD88-deficient patients, and empirical intravenous or subcutaneous IgG injections (400 mg/kg every 3 wk) in 15 IRAK-4-deficient and 4 MyD88-deficient patients. Patients were also immunized with *Str. pneumoniae* conjugated vaccine only (7/48 IRAK-4-deficient patients, 3/12 MyD88-deficient patients), nonconjugated vaccine only (8/48 IRAK-4-deficient patients, 1/12 MyD88-deficient patients), or both (9/48 IRAK-4-deficient patients, 3/12 MyD88-deficient patients); *H. influenzae* conjugated vaccine (21/48 IRAK-4-deficient patients, 8/12 MyD88-deficient patients); and *N. meningitidis* conjugated

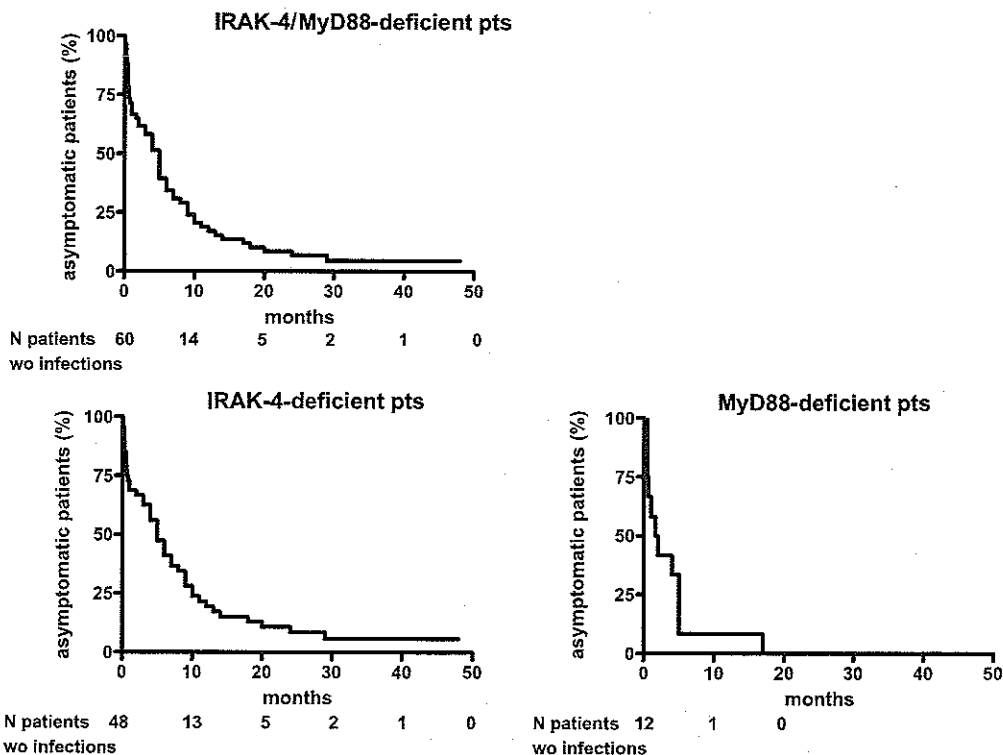

FIGURE 8. Epidemiologic features of IRAK-4 and MyD88 deficiency. Incidence of first bacterial infection in IRAK-4-deficient and MyD88-deficient patients during the first 50 months of life. (wo = without, pts = patients.)

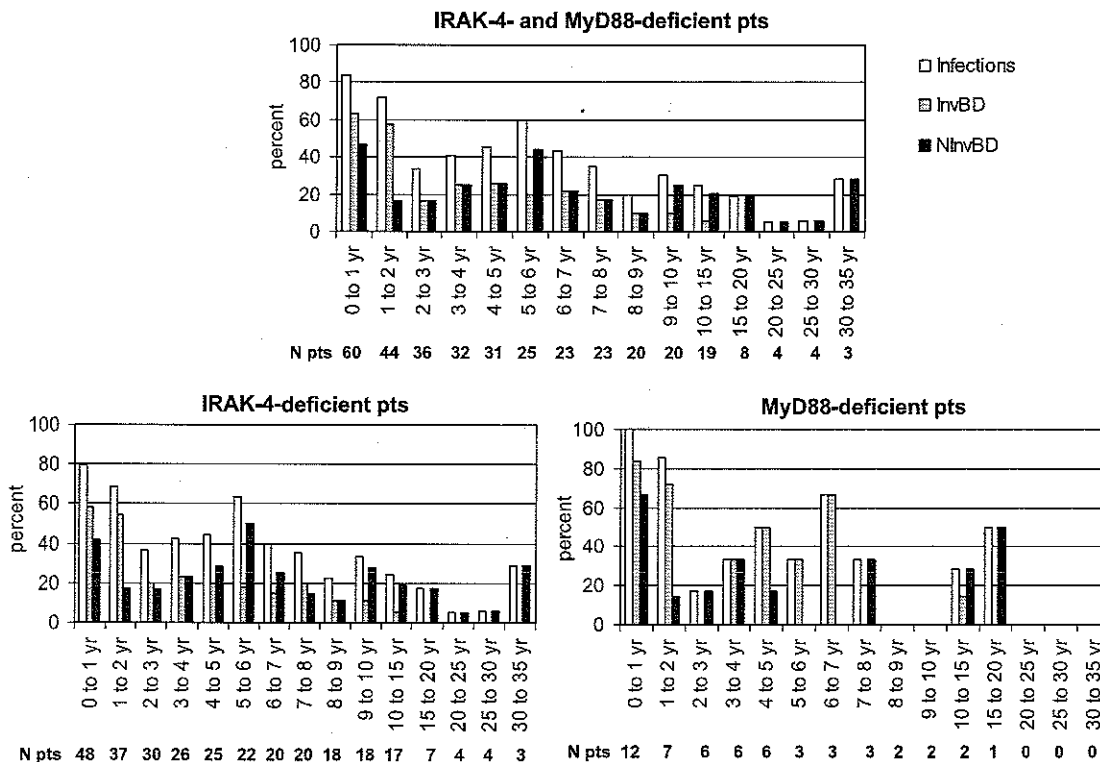

FIGURE 9. Annual rate of bacterial infections per patient, as a percentage. P = patients presenting at least 1 infection over the course of a year. Percent = P over the total number of patients.

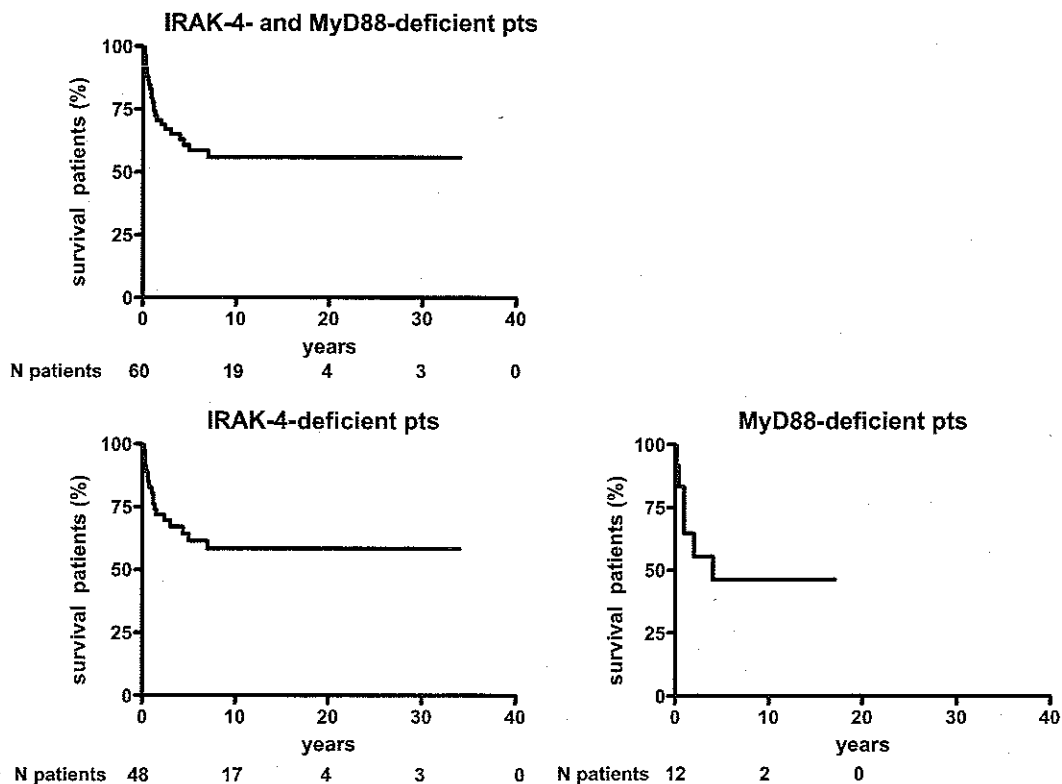

FIGURE 10. Survival curve of IRAK-4-deficient and MyD88-deficient patients.

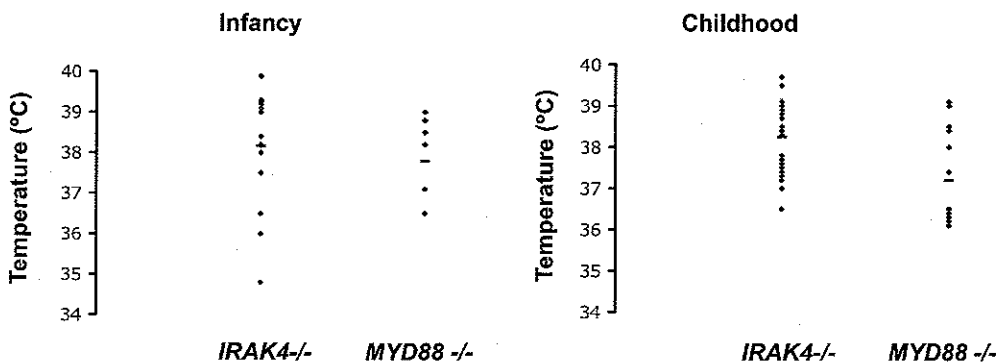

FIGURE 11. The inflammatory phenotype of IRAK-4/MyD88-deficiency. Temperature during bacterial infection in infancy and childhood.

or nonconjugated vaccine (12/48 IRAK-4-deficient patients, 7/12 MyD88-deficient patients).

We evaluated the impact of prophylaxis on the incidence of InvBD and their prognosis in all patients. Of all patients with documented bacterial infections, there was a total of 227 years and 152 years of follow-up without or with prophylaxis, respectively. At least 1 InvBD was observed in 35% of years without prophylaxis and in 16.4% of years on prophylactic treatment, and this difference was highly significant ($p = 10^{-3}$). We noted that no InvBD was documented in the 11 patients over the age of 14 years (10 IRAK-4-deficient patients and 1 MyD88-deficient patient), although only 4 of these patients continued to receive prophylactic treatment (antibiotics in 3 cases and antibiotics plus IgG infusions in the fourth case) (Figure 8; Table 10). For the 7 patients aged >14 years without prophylactic treatment, there was a total cumulative follow-up time of 49 years without any InvBD.

In conclusion, both IRAK-4 deficiency and MyD88 deficiency confer a predisposition to InvBD, mostly caused by *Str. pneumoniae*, *Staph. aureus*, and *P. aeruginosa*. In addition, both conditions confer a predisposition to NInvBD, often severe skin infections, mostly caused by *Staph. aureus*, and severe forms of ear, nose, and throat infections caused by *P. aeruginosa*. Clinical status and outcome both improve with age. There seems to be a beneficial role of prophylaxis combining intensive vaccinations, oral antibiotics, and IgG injections.

The most important advice for the families and physicians of IRAK-4-deficient and MyD88-deficient patients is to initiate empiric parenteral antibiotic treatment as soon as infection is suspected or the patient develops a moderate fever, without taking

inflammatory parameters into account, because patients may die from rapid invasive bacterial infection even if prophylactic measures are taken.

DISCUSSION

We provide here the first detailed description, to our knowledge, of the clinical features and outcome of a large series of patients with IRAK-4 and MyD88 deficiencies, a novel group of primary immunodeficiencies characterized by a selective and profound defect of TLR and IL-1R signaling. Patients with these 2 deficiencies are highly susceptible to InvBD caused by *Str. pneumoniae* and *Staph. aureus*, and to NInvBD caused by *Staph. aureus* and *P. aeruginosa*. NInvBD is largely restricted to the skin (*Staph. aureus*) and the upper respiratory tract (*P. aeruginosa*). By contrast, several sites are affected during InvBD, with abscesses of inner organs, lymph nodes and saliva glands, meningitis, and septicemia frequently observed. Recurrent invasive pneumococcal disease is a hallmark of these 2 primary immunodeficiencies. Infections typically run an acute, as opposed to chronic course. However, they may be difficult to diagnose, due to weak inflammatory signs that appear late. No chronic pulmonary disease is observed in these patients, and both acute bronchitis and pneumonitis are rare. Gastrointestinal and urogenital infections are also rare.

Finally, the lack of viral, parasitic, and fungal disease in these patients is striking and cannot merely result from medical prophylaxis, as proposed elsewhere,³³ because the prophylaxis used targets mostly pyogenic bacteria, and patients with no prophylaxis do not present such infections. The nature and sites of infections in patients with IRAK-4 and MyD88 deficiencies seem to be well delineated: mostly invasive pneumococcal

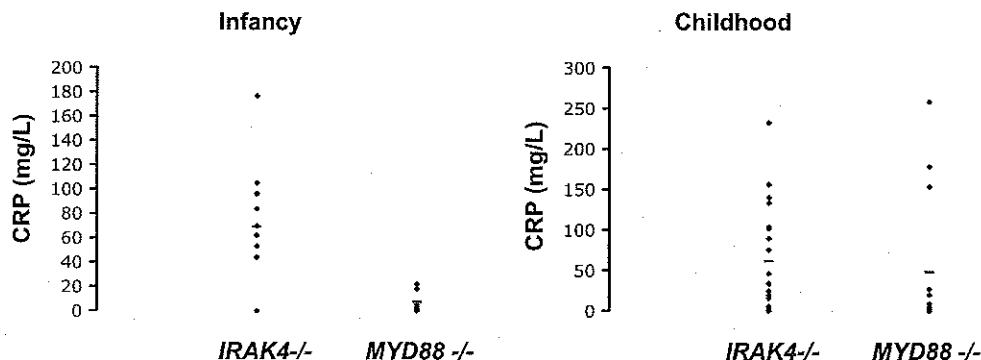

FIGURE 12. CRP concentration during bacterial infection in infancy and childhood.

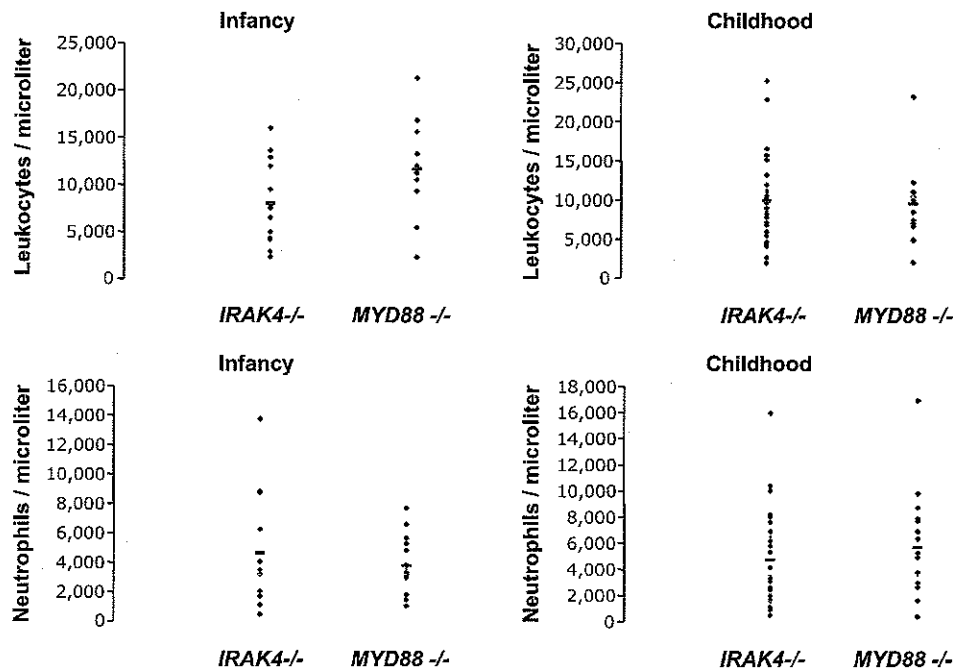

FIGURE 13. Polymorphonuclear neutrophil counts during bacterial infection in infancy and childhood.

disease, cutaneous and invasive staphylococcal disease, and *Pseudomonas* infection of the upper respiratory tract or peritoneum. It is striking that the range of infectious agents is much narrower than predicted from the mouse model of experimental infection: MyD88-deficient and IRAK-4-deficient mice are susceptible to more than 40 infectious agents.^{25,45} The sites of infection also provide us with unique information about the anatomical role of the TIR pathway in host defense.

The infectious phenotype of MyD88- or IRAK-4-deficient patients is related to but different from that observed in most patients with NEMO or IκBα deficiency, who generally display impairment of both TIR-signaling and other NF-κB-dependent immunologic pathways.⁷ Indeed, up to 85 patients with hypomorphic mutations of NEMO and 5 patients with hypermorphic mutations of IKBA have been reported.^{7,13,21,28,31} Some of these patients had developmental signs ranging from ectodermal dysplasia with osteopetrosis and lymphoedema to a complete absence of a developmental phenotype, whereas IRAK-4-deficient and MyD88-deficient patients have no signs of developmental impairment.⁷ The spectrum of infectious diseases is broad in NEMO-deficient and IκBα-deficient patients, as most patients present multiple infections, although some display a specific predisposition to pneumococcal or mycobacterial diseases.⁷ Almost all patients present infections caused by pyogenic bacteria, and only a few patients suffer from mycobacterial, fungal, and/or viral diseases. The most frequent pathogens observed include gram-positive (*Str. pneumoniae* and *Staph. aureus*) and gram-negative pyogenic bacteria (*P. aeruginosa* and *H. influenzae*). Patients bearing mutations in NEMO almost invariably have an impaired antibody response to glycans, including pneumococcal capsules in particular, as in half the IRAK-4- and MyD88-deficient patients explored for antibody responses to a subset of glycan antigens.⁴⁰ Thus, the bacterial diseases seen in NEMO-deficient patients are probably due in part to the impact of NEMO mutations on the TIR-signaling pathway. Conversely, the other infections seen in NEMO-deficient patients but not in

IRAK-4-deficient and MyD88-deficient patients probably reflect the impairment of other signaling pathways.

The association of clinical disease caused by *Str. pneumoniae*, *Staph. aureus*, and *P. aeruginosa* is unique among primary immunodeficiencies other than IRAK-4, MyD88, NEMO, and IκBα deficiencies.³⁷ Primary immunodeficiencies affecting bacterial opsonization and splenic phagocytosis are associated with invasive pneumococcal disease. These conditions include most B- and T-cell defects, congenital asplenia, deficiencies of C3, the early component of the classical and alternative complement pathway.³⁹ These patients develop recurrent invasive pneumococcal disease due to *Str. pneumoniae*, but are less susceptible to *Staph. aureus* and *P. aeruginosa* infections.

Other primary immunodeficiencies, such as STAT3 and TYK2 deficiencies in HyperIgE syndromes, are associated with staphylococcal infections,⁷ but patients with these primary immunodeficiencies do not suffer from invasive pneumococcal disease and *Pseudomonas* infection. Notably, two-thirds of the explored IRAK-4- and MyD88-deficient patients were found to have high levels of IgE, but these levels were modest with respect to the very high IgE levels described in STAT-3-deficient patients.

Finally, most primary immunodeficiencies involving phagocyte defects, including congenital neutropenia, leukocyte adhesion deficiency, and chronic granulomatous disease, are associated with severe infections caused by *P. aeruginosa* and *Staph. aureus*, but patients with these disorders are not particularly prone to invasive pneumococcal disease.³⁹ A diagnosis of IRAK-4 or MyD88 deficiency or of NEMO/IκBα-related defects should be considered even with only 1 or 2 of these 3 infections. Neonates, infants, and children with invasive pneumococcal disease, severe staphylococcal disease, or *Pseudomonas* lesions of the upper respiratory tract or peritoneum, particularly in cases of recurrence, should be tested for the NF-κB pathways, including the TIR pathway in particular.^{2,9} This list is not exclusive, as systemic shigellosis was

TABLE 8. Inflammatory Signs at Admission in Patients With IRAK-4 Deficiency Who Had InvBD

Age Group	Age at Onset	No. of Episodes*	Temperature (°C)			CRP (mg/L)			Whole Leukocyte Count (WLC/ μ L)			Neutrophil Count (NC/ μ L)		
			Mean	Max	SD	Mean	Max	SD	Mean	Max	SD	Mean	Max	SD
Neonatal period	7 d to 17 d	5 (T)	37.2	38.0	0.6	43.6	150	61.2	9550 (N: 2700–13,000)	18,000	6807	3525	5308	11,500
		5 (CRP)												
		5 (WLC)												
Infancy	5 wk to 11 mo	3 (NC)	38.2	39.9	1.4	69	176.4	51.1	8034 (N: 4300–9700)	16,000	4422	4643	13,760	3999
		16 (T)												
		12 (CRP)												
Childhood	1 yr to 14 yr	13 (WLC)	38.3	41.0	1.0	61.5	156	65.3	9875 (N: 4300–9700)	25,200	4894	4731	15,940	3593
		12 (NC)												
		27 (T)												
		22 (CRP)												
		36 (WLC)												
		31 (NC)												

*No. of patients for whom the following data were available: T = temperature, CRP = C-reactive protein concentration, WLC = whole leukocyte count, NC = neutrophil count.

TABLE 9. Inflammatory Signs at Admission in Patients With Myd88 Deficiency Who Had InvBD

Age Group	Age at Onset	No. of Episodes*	Temperature (°C)			CRP (mg/L)			Whole Leukocyte Count (WLC/ μ L)			Neutrophil Count (NC/ μ L)		
			Mean	Max	SD	Mean	Max	SD	Mean	Max	SD	Mean	Max	SD
Infancy	5 wk to 11 mo	7 (T)	38.1	39.0	1.3	7.2	6.5	21.8	11,691 (N: 4300–9700)	21,300	4964	3783	7680	1998
		12 (CRP)												
		14 (WLC)												
Childhood	1 yr to 10 yr	12 (NC)	37.2	39.1	1.1	47.7	153	83.7	9515 (N: 4300–9700)	23,200	4694	5693	16,900	4070
		17 (T)												
		14 (CRP)												
		16 (WLC)												
		15 (NC)												

*No. of patients for whom the following data were available: T = temperature, CRP = C-reactive protein concentration, WLC = whole leukocyte count, NC = neutrophil count.

TABLE 10. Prophylaxis

	IRAK-4-Deficient Patients	MyD88-Deficient Patients
Antibiotic prophylaxis	28/48	6/12
Penicillins	6	1
Cotrimoxazole	10	1
Penicillins plus cotrimoxazole	8	4
Cephalosporin	1	—
Azythromycin	1	—
Quinolone	2	—
IgG treatment	15/48	4/12
Antibiotic prophylaxis plus IgG treatment	13/48	4/12
No prophylaxis	18/48	6/12

documented in 2 patients, and other infectious diseases associated with these primary immunodeficiencies may be revealed by the investigation of other patients in the future.

In IRAK-4- and MyD88-deficient patients, clinical and laboratory signs of inflammation develop slowly even in cases of severe infection. The current study confirms and expands previous work indicating that CRP concentration, total leukocyte counts, and neutrophil numbers are typically low, but may also rise to appropriately high levels during prolonged infections, whereas temperature frequently remains inappropriately low even in such infections.¹⁸ Thus, weak signs of inflammation despite severe infection provide a further clue to possible defects in TIR signaling, although appropriately high levels of inflammatory signs do not rule out the diagnosis of TIR deficiency.¹⁸ Impairment of the production of IL-6-inducible molecules, such as CRP, may be observed. IRAK-4- and MyD88-deficient cells produce small amounts of IL-6 and IL-8 in vitro upon activation with IL-1 and TLR agonists.^{25,38,49} As CRP contributes to the clearance of pyogenic bacteria including pneumococcus,^{35,47} susceptibility to *Str. pneumoniae*, *Staph. aureus*, or *P. aeruginosa* may be increased by the slow rise in CRP levels. Similar delays in the development of signs of inflammation are observed in patients with NEMO and I κ B α deficiencies, whose broader susceptibility to infections includes these pyogenic bacteria.⁷

Some IRAK-4-deficient patients (n = 10) had a delay in umbilical cord detachment and/or omphalitis. Other primary immunodeficiencies, such as leukocyte adhesion deficiency type 1 and Rac2 deficiency, have been associated with late loss of the umbilical cord and/or omphalitis, but extremely high levels of circulating neutrophils and a lack of pus formation in peripheral tissues are classically found in these disorders.³⁶ By contrast, in IRAK-4- and MyD88-deficient patients, impaired polymorphonuclear neutrophil mobilization and/or frank neutropenia occurs from the onset of infection, perhaps secondary to the lack of IL-8 production. Despite this neutropenia, pus formation is normal in IRAK-4- and MyD88-deficient patients. The precise mechanism of cord separation is unknown, but it does require MyD88- and IRAK-4-dependent signals, as well as CD18-expressing leukocytes. Conversely, unlike patients with various phagocyte defects, such as chronic granulomatous disease, none of the IRAK-4- and MyD88-deficient patients had inflammatory bowel disease.³⁶

Despite conferring selective susceptibility to only a few bacteria, IRAK-4 and MyD88 deficiencies are nonetheless life-threatening in infancy and childhood, with a mortality rate of

38% in our series. Strikingly, however, although IRAK-4 and MyD88 appear to be vital in childhood, infections in patients lacking these proteins become rarer with age, with no death recorded in patients after the age of 8 years and no invasive infection after the age of 14 years, even in the absence of antibiotics or/and IgG prophylaxis in 7 patients over the age of 14 years. In total, this represents a cumulative time of 49 years without any InvBD for these patients. This dramatic improvement with age may be accounted for by adaptive antigen-specific T- and B-lymphocyte responses. Indeed, our patients displayed no detectable defect of protein antigen-specific T- and B-cell responses, although some patients were found to have weak antibody responses to a subset of glycan antigens.

Recent studies of neonatal bacterial sepsis in newborn mice suggest a reliance on innate immunity early in life, which progressively diminishes with age.⁵¹ An alternative complementary hypothesis is that innate immune responses may also mature with age.^{4,25} Other sensors, such as RIG-I-like helicases and NOD-like receptors, may progressively play a compensatory role. In any event, clinical improvement did not result solely from prophylaxis following diagnosis of the first infection or of the underlying deficit. The TIR pathway, including TLR responses in particular, remains dependent on IRAK-4/MyD88 with age, but the maturation of other pathways may gradually compensate for the lack of TIR signaling.

In this study, we show that the prognosis of IRAK-4 and MyD88 deficiencies is severe in infancy and early childhood, but improves substantially in adolescence. This finding is probably unique so far in the field of primary immunodeficiencies, which classically do not improve with age. This improvement with age is a hallmark of these conditions, not observed in other primary immunodeficiencies. A similar but less striking spontaneous improvement has been reported only in children with IL-12p40 and IL-12R β 1 deficiencies.¹⁰

ACKNOWLEDGMENTS

We thank the patients and their families for their trust and cooperation. We thank Lucile Janniere, Tony Leclerc, Martine Courat, Michele N'Guyen, Yelena Nemirovskaya, Chantal Harre, Corinne Jacques, Stéphanie N'Daga and Alexandra Arnold for excellent technical and secretarial assistance. We thank Drs François Dubos, Aurélie Lectayer, Corinne Levy, and Robert Cohen for their collaboration.

REFERENCES

- Akira S, Takeda K. Toll-like receptor signalling. *Nat Rev Immunol.* 2004;4:499–511.
- Alcasis A, Abcl L, Casanova JL. Human genetics of infectious diseases: between proof of principle and paradigm. *J Clin Invest.* 2009;119:2506–2514.
- Arend WP, Palmer G, Gabay C. IL-1, IL-18, and IL-33 families of cytokines. *Immunol Rev.* 2008;223:20–38.
- Belderbos ME, van Bleek GM, Levy O, Blanken MO, Houben ML, Schuijff L, Kimpen JL, Bont L. Skewed pattern of Toll-like receptor 4-mediated cytokine production in human neonatal blood: low LPS-induced IL-12p70 and high IL-10 persist throughout the first month of life. *Clin Immunol.* 2009;133:228–237.
- Borgers H, Moens L, Picard C, Jeurissen A, Raes M, Sauer K, Procsmans M, De Bocck K, Casanova JL, Meyts I, Bossuyt X. Laboratory diagnosis of specific antibody deficiency to pneumococcal capsular polysaccharide antigens by multiplexed bead assay. *Clin Immunol.* 2010;134:198–205.
- Bouma G, Doffinger R, Patel SY, Peskett E, Sinclair JC, Barcenas-Morales G, Cerron-Gutierrez L, Kumararatne DS,

- Davies EG, Thrasher AJ, Burns SO. Impaired neutrophil migration and phagocytosis in IRAK-4 deficiency. *Br J Haematol*. 2009;147:153–156.
7. Bustamante J, Boisson-Dupuis S, Jouanguy E, Picard C, Puel A, Abel L, Casanova JL. Novel primary immunodeficiencies revealed by the investigation of paediatric infectious diseases. *Curr Opin Immunol*. 2008;20:39–48.
 8. Cardenas M, von Bernuth H, Garcia-Saavedra A, Santiago E, Puel A, Ku CL, Emile JF, Picard C, Casanova JL, Colino E, Bordes A, Garfia A, Rodriguez-Gallego C. Autosomal recessive interleukin-1 receptor-associated kinase 4 deficiency in fourth-degree relatives. *J Pediatr*. 2006;148:549–551.
 9. Casanova JL, Abel L. Inborn errors of immunity to infection: the rule rather than the exception. *J Exp Med*. 2005;202:197–201.
 10. Casanova JL, Abel L. Primary immunodeficiencies: a field in its infancy. *Science*. 2007;317:617–619.
 11. Casrouge A, Zhang SY, Eidenschenk C, Jouanguy E, Puel A, Yang K, Alcais A, Picard C, Mahfoufi N, Nicolas N, Lorenzo L, Plancoulaine S, Senchal B, Geissmann F, Tabeta K, Hoebe K, Du X, Miller RL, Heron B, Mignot C, de Villemeur TB, Lebon P, Dulac O, Rozenberg F, Beutler B, Tardieu M, Abel L, Casanova JL. Herpes simplex virus encephalitis in human UNC-93B deficiency. *Science*. 2006;314:308–312.
 12. Chapel H, Puel A, von Bernuth H, Picard C, Casanova JL. Shigella sonnei meningitis due to interleukin-1 receptor-associated kinase-4 deficiency: first association with a primary immune deficiency. *Clin Infect Dis*. 2005;40:1227–1231.
 13. Courtois G, Smahi A, Reichenbach J, Doffinger R, Cancrini C, Bonnet M, Puel A, Chable-Bessia C, Yamaoka S, Feinberg J, Dupuis-Girod S, Bodemer C, Livadiotti S, Novelli F, Rossi P, Fischer A, Israel A, Munnich A, Le Deist F, Casanova JL. A hypermorphic IkappaBalpha mutation is associated with autosomal dominant anhidrotic ectodermal dysplasia and T cell immunodeficiency. *J Clin Invest*. 2003;112:1108–1115.
 14. Davidson DJ, Currie AJ, Bowdish DM, Brown KL, Rosenberger CM, Ma RC, Bylund J, Campsall PA, Puel A, Picard C, Casanova JL, Turvey SE, Hancock RE, Devon RS, Speert DP. IRAK-4 mutation (Q293X): rapid detection and characterization of defective post-transcriptional TLR/IL-1R responses in human myeloid and non-myeloid cells. *J Immunol*. 2006;177:8202–8211.
 15. Day N, Tangsinmankong N, Ochs H, Rucker R, Picard C, Casanova JL, Haraguchi S, Good R. Interleukin receptor-associated kinase (IRAK-4) deficiency associated with bacterial infections and failure to sustain antibody responses. *J Pediatr*. 2004;144:524–526.
 16. de Beaucoudrey L, Puel A, Filipe-Santos O, Cobat A, Ghandil P, Chrabich M, Feinberg J, von Bernuth H, Samarina A, Janniere L, Fieschi C, Stephan JL, Boileau C, Lyonnet S, Jondeau G, Cormier-Daire V, Le Merrer M, Hoarau C, Lebranchu Y, Lortholary O, Chandris MO, Tron F, Gambinri E, Bianchi L, Rodriguez-Gallego C, Zitnik SE, Vasconcelos J, Guedes M, Vitor AB, Marodi L, Chapel H, Reid B, Roifman C, Nadal D, Reichenbach J, Caragol I, Garty BZ, Dogu F, Camcioglu Y, Gulle S, Sanal O, Fischer A, Abel L, Stockinger B, Picard C, Casanova JL. Mutations in STAT3 and IL12RB1 impair the development of human IL-17-producing T cells. *J Exp Med*. 2008;205:1543–1550.
 17. Dinarello CA. Interleukin-1beta and the autoinflammatory diseases. *N Engl J Med*. 2009;360:2467–2470.
 18. Enders A, Pannicke U, Berner R, Henneke P, Radlinger K, Schwarz K, Ehl S. Two siblings with lethal pneumococcal meningitis in a family with a mutation in Interleukin-1 receptor-associated kinase 4. *J Pediatr*. 2004;145:698–700.
 19. Haraguchi S, Day NK, Nelson RP Jr, Emmanuel P, Duplantier JE, Christodoulou CS, Good RA. Interleukin 12 deficiency associated with recurrent infections. *Proc Natl Acad Sci U S A*. 1998;95:13125–13129.
 20. Hoarau C, Gerard B, Lescanne E, Henry D, Francois S, Lacapere JJ, El Benna J, Dang PM, Grandchamp B, Lebranchu Y, Gougerot-Pocidalo MA, Elbm C. TLR9 activation induces normal neutrophil responses in a child with IRAK-4 deficiency: involvement of the direct PI3K pathway. *J Immunol*. 2007;179:4754–4765.
 21. Janssen R, van Wengen A, Hoeve MA, ten Dam M, van der Burg M, van Dongen J, van de Vosse E, van Tol M, Bredius R, Ottenhoff TH, Weemaes C, van Disseel JT, Lankester A. The same IkappaBalpha mutation in two related individuals leads to completely different clinical syndromes. *J Exp Med*. 2004;200:559–568.
 22. Jeurissen A, Moens L, Raes M, Wuyts G, Willebrords L, Sauer K, Proesmans M, Ceuppens JL, De Boeck K, Bossuyt X. Laboratory diagnosis of specific antibody deficiency to pneumococcal capsular polysaccharide antigens. *Clin Chem*. 2007;53:505–510.
 23. Krause JC, Ghandil P, Chrabich M, Casanova JL, Picard C, Puel A, Creech CB. Very late-onset group B Streptococcus meningitis, sepsis, and systemic shigellosis due to interleukin-1 receptor-associated kinase-4 deficiency. *Clin Infect Dis*. 2009;49:1393–1396.
 24. Ku CL, Picard C, Erdos M, Jeurissen A, Bustamante J, Puel A, von Bernuth H, Filipe-Santos O, Chang HH, Lawrence T, Raes M, Marodi L, Bossuyt X, Casanova JL. IRAK4 and NEMO mutations in otherwise healthy children with recurrent invasive pneumococcal disease. *J Med Genet*. 2007;44:16–23.
 25. Ku CL, von Bernuth H, Picard C, Zhang SY, Chang HH, Yang K, Chrabich M, Issekutz AC, Cunningham CK, Gallin J, Holland SM, Roifman C, Ehl S, Smart J, Tang M, Barrat FJ, Levy O, McDonald D, Day-Good NK, Miller R, Takada H, Hara T, Al-Hajjar S, Al-Ghonatum A, Speert D, Sanlaville D, Li X, Geissmann F, Vivier E, Marodi L, Garty BZ, Chapel H, Rodriguez-Gallego C, Bossuyt X, Abel L, Puel A, Casanova JL. Selective predisposition to bacterial infections in IRAK-4-deficient children: IRAK-4-dependent TLRs are otherwise redundant in protective immunity. *J Exp Med*. 2007;204:2407–2422.
 26. Kuhns DB, Long Priel DA, Gallin JI. Endotoxin and IL-1 hyporesponsiveness in a patient with recurrent bacterial infections. *J Immunol*. 1997;158:3959–3964.
 27. Lavine E, Somech R, Zhang JY, Puel A, Bossuyt X, Picard C, Casanova JL, Roifman CM. Cellular and humoral aberrations in a kindred with IL-1 receptor-associated kinase 4 deficiency. *J Allergy Clin Immunol*. 2007;120:948–950.
 28. Lopez-Granados E, Kecnan JE, Kinney MC, Leo H, Jain N, Ma CA, Quinones R, Gelfand EW, Jain A. A novel mutation in NFKBIA/IKBA results in a degradation-resistant N-truncated protein and is associated with ectodermal dysplasia with immunodeficiency. *Hum Mutat*. 2008;29:861–868.
 29. Manroe BL, Weinberg AG, Rosenfeld CR, Browne R. The neonatal blood count in health and disease. I. Reference values for neutrophilic cells. *J Pediatr*. 1979;95:89–98.
 30. McDonald DR, Brown D, Bonilla FA, Geha RS. Interleukin receptor-associated kinase-4 deficiency impairs Toll-like receptor-dependent innate antiviral immune responses. *J Allergy Clin Immunol*. 2006;118:1357–1362.
 31. McDonald DR, Mooster JL, Reddy M, Bawle E, Secord E, Geha RS. Heterozygous N-terminal deletion of IkappaBalpha results in functional nuclear factor kappaB haploinsufficiency, ectodermal dysplasia, and immune deficiency. *J Allergy Clin Immunol*. 2007;120:900–907.
 32. Medvedev AE, Lentschat A, Kuhns DB, Blanco JC, Salkowski C, Zhang S, Arditi M, Gallin JI, Vogel SN. Distinct mutations in IRAK-4 confer hyporesponsiveness to lipopolysaccharide and interleukin-1 in a patient with recurrent bacterial infections. *J Exp Med*. 2003;198:521–531.
 33. Medzhitov R. Approaching the asymptote: 20 years later. *Immunity*. 2009;30:766–775.

34. Minegishi Y, Saito M, Tsuchiya S, Tsuge I, Takada H, Hara T, Kawamura N, Ariga T, Pasic S, Stojkovic O, Metin A, Karasuyama H. Dominant-negative mutations in the DNA-binding domain of STAT3 cause hyper-IgE syndrome. *Nature*. 2007;448:1058–1062.
35. Mold C, Du Clos TW. C-reactive protein increases cytokine responses to *Streptococcus pneumoniae* through interactions with Fc gamma receptors. *J Immunol*. 2006;176:7598–7604.
36. Ochs H, Edvard Smith CI, Puck JM. *Primary Immunodeficiency Diseases: A Molecular and Genetic Approach*. 2nd ed. New York: Oxford University Press; 2007.
37. Picard C, Casanova JL, Abel L. Mendelian traits that confer predisposition or resistance to specific infections in humans. *Curr Opin Immunol*. 2006;18:383–390.
38. Picard C, Puel A, Bonnet M, Ku CL, Bustamante J, Yang K, Soudais C, Dupuis S, Feinberg J, Fieschi C, Elbim C, Hitchcock R, Lammas D, Davies G, Al-Ghonaïum A, Al-Rayes H, Al-Jumaah S, Al-Hajjar S, Al-Mohsen IZ, Frayha HH, Rucker R, Hawn TR, Aderem A, Tufenkeji H, Haraguchi S, Day NK, Good RA, Gougerot-Pocidallo MA, Ozinsky A, Casanova JL. Pyogenic bacterial infections in humans with IRAK-4 deficiency. *Science*. 2003;299:2076–2079.
39. Picard C, Puel A, Bustamante J, Ku CL, Casanova JL. Primary immunodeficiencies associated with pneumococcal disease. *Curr Opin Allergy Clin Immunol*. 2003;3:451–459.
40. Puel A, Picard C, Ku CL, Smahi A, Casanova JL. Inherited disorders of NF-kappaB-mediated immunity in man. *Curr Opin Immunol*. 2004;16:34–41.
41. Qin J, Qian Y, Yao J, Grace C, Li X. SIGIRR inhibits interleukin-1 receptor- and toll-like receptor 4-mediated signaling through different mechanisms. *J Biol Chem*. 2005;280:25233–25241.
42. Suzuki N, Saito T. IRAK-4—a shared NF-kappaB activator in innate and acquired immunity. *Trends Immunol*. 2006;27:566–572.
43. Suzuki N, Suzuki S, Yeh WC. IRAK-4 as the central TIR signaling mediator in innate immunity. *Trends Immunol*. 2002;23:503–506.
44. Takada H, Yoshikawa H, Imaizumi M, Kitamura T, Takeyama J, Kumaki S, Nomura A, Hara T. Delayed separation of the umbilical cord in two siblings with Interleukin-1 receptor-associated kinase 4 deficiency: rapid screening by flow cytometer. *J Pediatr*. 2006;148:546–548.
45. Takeda K, Akira S. Toll-like receptors in innate immunity. *Int Immunol*. 2005;17:1–14.
46. van Bruggen R, Drewniak A, Tool AT, Jansen M, van Houdt M, Geissler J, van den Berg TK, Chapel H, Kuijpers TW. Toll-like receptor responses in IRAK-4-deficient neutrophils. *J Innate Immun*. 2010;2:280–287.
47. Volanakis JE. Human C-reactive protein: expression, structure, and function. *Mol Immunol*. 2001;38:189–197.
48. von Bernuth H, Ku CL, Rodriguez-Gallego C, Zhang S, Garty BZ, Marodi L, Chapel H, Chrabieh M, Miller RL, Picard C, Puel A, Casanova JL. A fast procedure for the detection of defects in Toll-like receptor signaling. *Pediatrics*. 2006;118:2498–2503.
49. von Bernuth H, Picard C, Jin Z, Pankla R, Xiao H, Ku CL, Chrabieh M, Mustapha IB, Ghandil P, Camcioglu Y, Vasconcelos J, Sirvent N, Guedes M, Vitor AB, Herrero-Mata MI, Arostegui JJ, Rodrigo C, Alsina L, Ruiz-Ortiz E, Juan M, Fortuny C, Yague J, Anton J, Pascal M, Chang HH, Janniere L, Rose Y, Garty BZ, Chapel H, Issekutz A, Marodi L, Rodriguez-Gallego C, Banchereau J, Abel L, Li X, Chaussabel D, Puel A, Casanova JL. Pyogenic bacterial infections in humans with MyD88 deficiency. *Science*. 2008;321:691–696.
50. Wernette CM, Frasch CE, Madore D, Carlone G, Goldblatt D, Plikaytis B, Benjamin W, Quataert SA, Hildreth S, Sikkema DJ, Kayhty H, Jonsdottir I, Nahm MH. Enzyme-linked immunosorbent assay for quantitation of human antibodies to pneumococcal polysaccharides. *Clin Diagn Lab Immunol*. 2003;10:514–519.
51. Wynn JL, Scumpia PO, Winfield RD, Delano MJ, Kelly-Scumpia K, Barker T, Ungaro R, Levy O, Moldawer LL. Defective innate immunity predisposes murine neonates to poor sepsis outcome but is reversed by TLR agonists. *Blood*. 2008;112:1750–1758.
52. Yang K, Puel A, Zhang S, Eidenschenk C, Ku CL, Casrouge A, Picard C, von Bernuth H, Senechal B, Plancoulaine S, Al-Hajjar S, Al-Ghonaïum A, Marodi L, Davidson D, Speert D, Roifman C, Garty BZ, Ozinsky A, Barrat FJ, Coffman RL, Miller RL, Li X, Lebon P, Rodriguez-Gallego C, Chapel H, Geissmann F, Jouanguy E, Casanova JL. Human TLR-7-, -8-, and -9-mediated induction of IFN-alpha/beta and -lambda is IRAK-4 dependent and redundant for protective immunity to viruses. *Immunity*. 2005;23:465–478.
53. Zhang Q, Davis JC, Lamborn IT, Freeman AF, Jing H, Favreau AJ, Matthews HF, Davis J, Turner ML, Uzel G, Holland SM, Su HC. Combined immunodeficiency associated with DOCK8 mutations. *N Engl J Med*. 2009;361:2046–2055.
54. Zhang SY, Jouanguy E, Ugolini S, Smahi A, Elain G, Romero P, Segal D, Sancho-Shimizu V, Lorenzo L, Puel A, Picard C, Chappier A, Plancoulaine S, Titeux M, Cognet C, von Bernuth H, Ku CL, Casrouge A, Zhang XX, Barreiro L, Leonard J, Hamilton C, Lebon P, Heron B, Vallee L, Quintana-Murci L, Hovnanian A, Rozenberg F, Vivier E, Geissmann F, Tardieu M, Abel L, Casanova JL. TLR3 deficiency in patients with herpes simplex encephalitis. *Science*. 2007;317:1522–1527.